

# mze

MZ ELECTRONIC



Verricelli / Windlasses



Eliche & Timoni / propeller & rudders



Eliche di manovra / Thrusters



Eliche di manovra / Thrusters



REV.29

**mze**  
MZ ELECTRONIC

# INDICE INDEX

## 11 • VERRICELLI *Windlasses*



### 14 • RAME ORO & NERO *Copper Gold & Black*



### 17 • VERTICALI *Vertical*



### 36 • ORIZZONTALI *Horizontal*



### 51 • TONNEGGI *Capstans*



## 67 • ACCESSORI *Accessories*



### 68 • BLOCCA CATENA *Chain Stopper*



### 70 • CONTAMETRI *Chain Counter*



### 75 • RADIOCOMANDI *Remote Control*



### 76 • PULSANTIERE *Hand Held Control Units*



### 78 • CONTATTORI *Contactors*



### 80 • ACCESSORI *Accessories*



## 85 • LINEA ENERGIA *Energy Line*



### 86 • CARICA BATTERIE *Battery Chargers*



### 88 • RIPARTITORI DI CARICA *Charge Distributors*



# INDICE INDEX

## 89 • ELICHE DI MANOVRA Craftsman *Craftsman Thrusters*



### 91 • ELICHE ELETTRICHE *Electric thrusters*



### 93 • ELICHE IDRAULICHE *Hydraulic thrusters*



### 94 • ACCESSORI *Accessories*



## 97 • ELICHE DI MANOVRA Italwinch *Italwinch Thrusters*

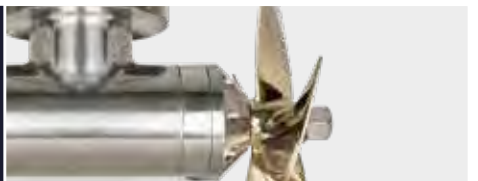

### 99 • ELICHE ELETTRICHE *AC Thrusters*



### 100 • ELICHE IDRAULICHE *Hydraulic Thrusters*



### 102 • ACCESSORI *Accessories*



## 105 • PROGETTO ELICA



### 107 • ELICHE DI SUPERFICE *Surface piercing propeller*



### 109 • ELICHE IMMERSE *Submerged propeller*



### 111 • TIMONI BRONZO *Bronze rudders*

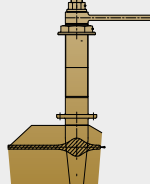

### 113 • TIMONI INOX *Stainless steel rudders*

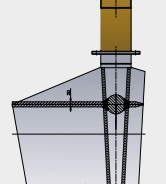

### 116 • SUPPORTI *Brackets*



### 117 • LINEE D'ASSE *Shaft lines*



### 118 • TENUTE E FLANGE *shaft, shaft coupling, shaft seal*







# mze

MZ ELECTRONIC

**MZ Electronic** nasce nel 1993 come azienda per la progettazione e lo sviluppo di apparecchiature elettroniche. Sin dai primi anni l'azienda produce un proprio catalogo, presentandosi alle principali fiere italiane ed estere. Negli anni dello sviluppo della nautica, **MZ Electronic** incrementa la propria gamma di prodotti: caricabatteria, ripartitori di carica, interruttori di sentina ed ovviamente accessori per i verricelli.

*MZ Electronic was founded in 1993 as a company for design and development of electronic equipment. Since the beginning, the company has produced its own catalogue, presenting itself at the main Italian and foreign trade fairs. Over the years of development in nautical sector, MZ Electronic increased its range of products: battery chargers, charge distributors, bilge pump switches and obviously windlass accessories.*



2008

**MZ Electronic inizia a collaborare con ORVEA, creando il marchio per salpa ancora Italwinch ed iniziando a realizzare la prima gamma di verricelli per imbarcazioni fino ai 16 metri.**

*MZ Electronic starts collaborating with ORVEA, creating the Italwinch windlass brand and starting to produce the first range of windlasses for boats up to 16 meters.*



**MZ Electronic acquisisce ORVEA, ingrandendo la famiglia dei prodotti legati all'ormeggio fino ad imbarcazioni da 40 metri, ottenendo quindi una gamma completa di accessori elettronici e la possibilità di realizzare prodotti meccanici personalizzati.**

*MZ Electronic acquires ORVEA, widening the family of mooring products for boats up to 40 metres, thus obtaining a complete range of electronic accessories and the possibility of creating customized mechanical products.*



2011



**MZ Electronic** completa l'acquisizione della **Officina Navale Nanni (ONN)**, localizzata nella cittadina toscana di Viareggio, famoso polo nautico conosciuto in tutto il mondo. **ONN**, nata nel 1950, ha da sempre realizzato verricelli salpa ancora personalizzati in base alle richieste dei progettisti. **ONN** ha portato **MZ Electronic** a poter fornire imbarcazioni da diporto, commerciali e militari fino a 90 metri di lunghezza.

*MZ Electronic completes the acquisition of Officina Navale Nanni (ONN), located in Viareggio, a famous nautical hub known all over the world. ONN was born in 1950, has always made customized windlasses, according to the requests of the designers. ONN has led MZ Electronic to be able to supply pleasure, commercial and military boats up to 90 meters.*

# 2017



# 2021

**MZ Electronic** acquisisce **Progetto Elica (SBM)**, ditta specializzata nel calcolo, nella progettazione e produzione di eliche personalizzate, sia immerse che di superficie, linee d'asse e timoni, per imbarcazioni fino a 150 piedi.

*MZ Electronic acquires Progetto Elica (SBM), a company specialized in the calculation, design and production of customized submerged and surface propellers, shaft lines and rudders, for boats up to 150 feet.*



# 2023

MZ Electronic compie 30 anni e dispone oggi di una gamma di prodotti sempre più completa e di alta qualità, dalla propulsione all'ancoraggio e tutti certificabili in base ai requisiti degli enti di classificazione più severi al mondo.

*MZ Electronic celebrates its 30th anniversary and provides now a more and more complete high quality range of products, from propulsion to anchoring and all certifiable according to the requirements of the strictest classification bodies in the world.*







## RETE VENDITA ITALIA

### PIEMONTE, LOMBARDIA, DA PROV. DI PIACENZA A MODENA

**MZ Electronic S.r.l.**  
Tel: 039 2148126  
Cell: 334 1005313  
Fax: 039 2146244  
e-mail: [vendite@mzelectronic.it](mailto:vendite@mzelectronic.it)

### LIGURIA

**MZ Electronic S.r.l.**  
Tel: 039 2148126  
Cell: 334 1005313  
Fax: 039 2146244  
e-mail: [vendite@mzelectronic.it](mailto:vendite@mzelectronic.it)

### FRIULI VENEZIA GIULIA VENETO

**AGENTE Maurizio Grisoni**  
Cell: 335 5427510  
Fax: 040 201398  
e-mail: [maurizio@grisoni.net](mailto:maurizio@grisoni.net)

### TOSCANA

**MZ Electronic S.r.l.**  
Tel: 039 2148126  
Cell: 334 1005313  
Fax: 039 2146244  
e-mail: [vendite@mzelectronic.it](mailto:vendite@mzelectronic.it)

### LAZIO E CAMPANIA

**AGENTE Diego Cipolletta**  
Cell: 338 3521939  
Fax: 081 5765612  
e-mail: [cipollettadiago@gmail.com](mailto:cipollettadiago@gmail.com)

### PUGLIA E BASILICATA

**AGENTE Francesco Caforio**  
Cell: 338 8624715  
Fax: 0832 733384  
e-mail: [fcaforio@gmail.com](mailto:fcaforio@gmail.com)

### SICILIA E CALABRIA

**AGENTE Giuseppe Caccamo**  
Tel: 095 4032150  
Cell: 348 6036031  
Fax: 095 495869  
e-mail: [info@giuseppecaccamo.com](mailto:info@giuseppecaccamo.com)

### EMILIA ROMAGNA MARCHE E ABRUZZO

**AGENTE Giuseppe Ballarini**  
Cell: 335 284009  
Fax: 0721 390150  
e-mail: [tradeevolutionsnc@gmail.com](mailto:tradeevolutionsnc@gmail.com)

### SARDEGNA

**AGENTE Gerolamo Gala**  
Cell 340 6246822  
e-mail: [gerolamogala@gmail.com](mailto:gerolamogala@gmail.com)

# RETE VENDITA ESTERA

## SPAIN PORTUGAL

### IMNASA IMPORTACIONES NAUTICAS S.A.

Tel: +34 972481100  
Fax: +34 972481116  
e-mail: [imnasa@imnasa.com](mailto:imnasa@imnasa.com)  
web: [www.imnasa.com](http://www.imnasa.com)

## FRANCE

### VDM - REYA SAS

Tel: +33 494 086 820  
Fax: +33 494 082 659  
e-mail: [contact@vdm-reya.com](mailto:contact@vdm-reya.com)  
web: [www.vdm-reya.com](http://www.vdm-reya.com)

### ACCASTILLAGE DIFFUSION INTERMER

web: [www.accastillage-diffusion.com](http://www.accastillage-diffusion.com)

### SEIMI SAS

Tel: +33 298461102  
Fax: +33 298433749  
e-mail: [info@seimi.com](mailto:info@seimi.com)  
web: [www.seimi.com](http://www.seimi.com)

## HOLLAND BELGIUM

### EXALTO B.V.

Tel: +31 (0)184 615 800  
Fax: +31 (0)184 614 045  
e-mail: [sales@exalto.com](mailto:sales@exalto.com)  
web: [www.exalto.com](http://www.exalto.com)

## UNITED KINGDOM IRELAND

### MARATHON

Tel: +44 2392 637711  
e-mail: [sales@marathonleisure.co.uk](mailto:sales@marathonleisure.co.uk)  
web: [www.marathonleisure.co.uk](http://www.marathonleisure.co.uk)

## MALTA

### STUART MARINE

Tel: +356 21570962  
Fax: +356 99456487  
e-mail: [stuart@maltanet.net](mailto:stuart@maltanet.net)  
web: [www.stuartmarinemalta.net](http://www.stuartmarinemalta.net)

## USA - CARIBBEAN

### BAINBRIDGE INTERNATIONAL

Tel: +1 954 532 7557  
NORTHEAST - Canton (Massachusetts)  
SOUTHEAST - Pompano Beach (Florida)  
WEST - Huntington Beach (California)  
e-mail: [info@bainbridgeintusa.com](mailto:info@bainbridgeintusa.com)  
web: [www.bainbridgeintusa.com](http://www.bainbridgeintusa.com)

## CROATIA

### SRETNI VAL D.O.O.

Tel: 00385/21320917  
Fax: 00385/21320918  
e-mail: [gojsasplit@gmail.com](mailto:gojsasplit@gmail.com)  
web: [www.lucky-wave.eu](http://www.lucky-wave.eu)

## GREECE

### D. KORONAKIS S.A.

Tel: +30 210 4060 600  
Fax: +30 210 4615 211  
e-mail: [koronakis@koronakis.gr](mailto:koronakis@koronakis.gr)  
web: [www.koronakis.gr](http://www.koronakis.gr)

## TURKEY

### SARAY DENIZ MALZEMERI

Tel: +90 (0)212 221 13 63  
Fax: +90 (0)212 220 99 91  
e-mail: [saray@saray.com.tr](mailto:saray@saray.com.tr)  
web: [www.saray.com.tr](http://www.saray.com.tr)

## AUSTRIA CZECH REPUBLIC SLOVAC REPUBLIC

### G. ASCHERL GMBH

Tel: +43 5574 89900-0  
Fax: +43 5574 89900-10  
e-mail: [office@ascherl.at](mailto:office@ascherl.at)  
web: [www.ascherl.at](http://www.ascherl.at)

## BRASIL

### I-SEA GROUP

VILA ANDRADE - SAO PAULO - SP  
Tel: +5511 2645-4877  
PORTO BELO - SC  
Tel: +5551 9992-57576  
VILA FUNCHAO - GUARUJA - SP  
Tel: +5511 9828-97430  
e-mail: [info@i-sea.com.br](mailto:info@i-sea.com.br)  
web: [www.i-sea.com.br](http://www.i-sea.com.br)

## TAIWAN

### TRIMARINE TAIWAN

Tel: +886 7 3329 388  
Fax: +886 7 3339 788  
e-mail: [tritex@ms74.hinet.net](mailto:tritex@ms74.hinet.net)  
web: [www.tritex.com.sg](http://www.tritex.com.sg)

## CROATIA SLOVENIA MONTENEGRO SERBIA

### UNIMAR RIJEKA D.O.O.

Tel: +385 51 623 263  
Fax: +385-51-512537  
e-mail: [unimar@unimar.hr](mailto:unimar@unimar.hr)  
web: [www.unimar.org](http://www.unimar.org)

## AUSTRALIA

## NEW ZEALAND

### OZZI MARINE PTY LTD

Tel: +61 (0) 7 5665 7185  
e-mail: [info@ozzimarine.com.au](mailto:info@ozzimarine.com.au)  
web: [www.ozzimarine.com.au](http://www.ozzimarine.com.au)

## NORWAY

### MARINESHOP AS

Tel: +47 69 16 06 00  
e-mail: [post@marineshop.no](mailto:post@marineshop.no)  
Web: [www.marineshop.no](http://www.marineshop.no)

## POLAND

### MAZURIA

Tel: +48 89 761 2165  
Fax: +48 89 761 2221  
e-mail: [mazuria@mazuria.com](mailto:mazuria@mazuria.com)  
web: [www.mazuria.com](http://www.mazuria.com)

## U.A.E. QATAR OMAN KUWAIT SAUDI ARABIA BAHRAIN

### EMPIRE MARINE INTERNATIONL LCC

Tel: +971 4 3240 300  
e-mail: [info@empire-marine.com](mailto:info@empire-marine.com)  
web: [www.empire-marine.com](http://www.empire-marine.com)

## CHINA

### HOLYLIGHT TRADING CO. LTD

Tel: +86 0755 2667 0700  
Fax: +86 0755 2682 9418  
e-mail: [lya@holylight-marine.com](mailto:lya@holylight-marine.com)  
web: [www.hollylight-marine.com](http://www.hollylight-marine.com)

## ISRAEL

### MARINE L.T.D.

Tel: +972 4 6961651  
Fax: +972 4 6961652  
e-mail: [david@haifamarine.co.il](mailto:david@haifamarine.co.il)  
web: [www.haifamarine.co.il](http://www.haifamarine.co.il)

## RUSSIA

### TECHNOMARIN GROUP

Tel: +7 (812)6778822  
e-mail: [info@technomarin.ru](mailto:info@technomarin.ru)  
web: [www.technomarin.ru](http://www.technomarin.ru)

### «1000 SIZES» LLC

tel: +7 (423) 260-15-15  
e-mail: [offerjp@1000size.ru](mailto:offerjp@1000size.ru)  
web: [opt.1000size.ru](http://opt.1000size.ru)

## SVEZIA

### SEASEA

Tel: +46 08-50564 040  
e-mail: [info@seasea.se](mailto:info@seasea.se)  
web: [www.seasea.se](http://www.seasea.se)

## NEW CALEDONIA

### LIMOUSIN MARINE SARL

Tel: +687 28 22 95  
Fax: +687 27 68 70  
e-mail: [limousin@limousin.nc](mailto:limousin@limousin.nc)  
web: [www.limousin-marine.nc](http://www.limousin-marine.nc)

## SINGAPORE

### ALQUEST MARINE PTE LTD

Tel: +65 67499359  
Fax: +65 67499360  
e-mail: [jimmy.goh@alquest.com.sg](mailto:jimmy.goh@alquest.com.sg)  
Web: [www.alquest.com.sg](http://www.alquest.com.sg)

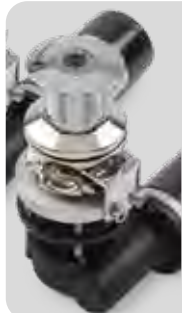

PAGINA 11

MZ Electronic inizia a collaborare con ORVEA nel 2008, creando da subito il marchio Italwinch ed iniziando a realizzare la prima gamma di verricelli. Ora Italwinch è un marchio leader nel settore dell'ormeggio che produce grazie all'acquisizione dell'Officina Navale Nanni, verricelli per imbarcazioni fino ai 90mt.

*MZ Electronic started working with ORVEA in 2008, immediately creating the Italwinch brand and starting to create the first range of winches. Now Italwinch is a leading brand in the mooring sector, which produces, thanks for acquisition the Officina Navale Nanni winches for boats up to 90 meters.*



## Accessori / Accessories

PAGINA 67

MZ Electronic produce una vasta gamma di accessori inerente il funzionamento dei verricelli. Negli anni dello sviluppo della nautica, MZ Electronic incrementa la propria gamma di prodotti: interruttori di sentina, contattori ed invertitori, radiocontometri e pulsantiere. L'azienda tuttora progetta, sviluppa e produce schede elettroniche per il mercato nautico, per diverse applicazioni, dal software, alla custodia della scheda stessa.

*MZ Electronic produces a wide range of accessories relating to the operation of winches. In the years of nautical development, MZ Electronic increases its product range: bilge pump switches, contactors and inverters, remote control chain counter and hand held remote control units. The company still designs, develops and produces electronic boards for the nautical market, for different applications, from software to the boards' case.*



## Linea Energia / Energy Line

PAGINA 85

La storia della Mz Electronic è rappresentata dalla linea energia. Fin dalla nascita, infatti, Mz ha sviluppato prodotti quali carica batteria, inverter ad onda pura e ripartitori di carica. L'ultimo nato in casa Mz è un caricabatteria completamente in acciaio inox da 25A a 3 uscite.

*The history of Mz Electronic is represented by the energy line. In fact, since its origin, Mz has developed products such as battery chargers, pure sine wave inverters and charge distributors. The latest addition to Mz is a completely stainless steel 25 A 3-main output*



PAGINA 89

Craftsman Marine è una delle aziende leader nella progettazione e ingegnerizzazione di una vasta gamma di eliche di manovra per imbarcazioni da diporto e commerciali.

*Craftsman Marine is one of the leading companies which designs and produces a wide variety thrusters for pleasure crafts and light commercial vessels.*



PAGINA 97

Le eliche di manovra Italwinch nascono da un'attenta e accurata progettazione grazie al know-how oltre ventennale che vanta l'azienda. Sviluppate specificatamente per superyacht e megayacht si contraddistinguono per il corpo in acciaio e le eliche a 4 pale in Nibral.

*Italwinch thrusters are born from a careful planning thanks to the over twenty years know-how which the company boasts. Developed specifically for superyachts and megayachts, they stand out for the steel body and the 4-blade Nibral propellers.*



PAGINA 105

Progetto Elica nasce dall'esperienza di SBM, storica azienda di eliche italiana nata nel 1963. Siamo specializzati nel calcolo, nella progettazione e produzione di eliche personalizzate, sia immerse che di superficie, linee d'asse e timoni.

*Progetto Elica was born from the experience of SBM, an historic Italian propeller company founded in 1963. We are specialized in the design and production of custom-made propellers (both fully submerged and surface piercing), shaft lines and rudders for boats.*

**VERRICELLI**  
WINDLASSES

**PAG.17**

**VERTICALI**

*VERTICAL*



**PAG.36**

**ORIZZONTALI**

*HORIZONTAL*



**PAG.51**

**DA TONNEGGIO**

*CAPSTAN*





# SCEGLIERE IL SALPA ANCORA CORRETTO PER L'IMBARCAZIONE

## HOW TO CHOOSE THE CORRECT WINDLASS FOR YOUR BOAT

### INFORMAZIONI PRELIMINARI

#### PRELIMINARY INFORMATION

Le principali informazioni da conoscere per una corretta scelta sono:

*The most important information for a correct windlass choice is:*

- Lunghezza dell'imbarcazione  
*Length of the boat*
- Peso totale di ancora e catena  
*Anchor and chain total weight*
- Tipo di alimentazione disponibile a bordo per alimentare il verricello (12V - 24V - 230V - 400V - Idraulica)  
*Onboard power supply to power the windlass (12V - 24V - 230V - 400V - Hydraulic)*
- Caratteristiche di coperta e spazio disponibile nel gavone  
*Deck characteristics and space available in the peak*
- Tipologia d'uso dell'imbarcazione  
*Boat use typology*

### SCELTA DEL SALPA ANCORA

#### HOW TO CHOOSE THE WINDLASS

I parametri da considerare nella scelta del salpa ancora sono lunghezza della barca e peso totale dell'ormeggio. In base alla lunghezza della barca si definisce la taglia del verricello, in base al peso totale dell'ormeggio (ancora più catena) si calcola la potenza necessaria. Importante definire il significato dei due valori di carico che troverete riportati nelle caratteristiche tecniche dei salpa ancora:  **tiro istantaneo massimo**, che rappresenta il picco di carico che il verricello può sopportare per un limitato periodo di tempo, raggiunto solitamente nel momento in cui si deve disincagliare l'ancora dal fondale e **carico di lavoro al sollevamento**, che rappresenta il carico che il verricello può sopportare con una certa continuità. Moltiplicando per il fattore 4 il peso totale dell'ormeggio si determina il carico di lavoro massimo istantaneo, che deve avere il verricello scelto, definendone quindi la potenza.

*Parameters which have to be considered for a correct windlass choice are the length of the boat and ground tackle. According to the length of the boat you can find out windlass size, making reference to the ground tackle weight (anchor and chain), you can calculate power needed. It is important to define the meaning of the two values that you will find in windlasses' technical features: **maximum pull**, which represents maximum peak load that the windlass can bear for a limited time, which normally occurs when the anchor is released from the bottom **and lift working load**, which means the load that the windlass can bear continuously. Multiplying for the coefficient 4 the ground tackle weight, you will determine MAXIMUM PULL that windlass must have, defining this way its power.*

**Peso totale ormeggio x 4 <= carico di lavoro massimo istantaneo verricello**

*Ground tackle weight x 4 <= MAXIMUM PULL of the windlass*



Vogliamo ricordare che queste rimangono sempre indicazioni di massima e che le soluzioni adottabili possono variare in relazione a diversi fattori, come la modalità di utilizzo, il peso della barca, le condizioni del mare, etc.

*We remind you that these are standard rules, which can change according to several conditions, as the device employment, boat weight, weather conditions etc.*

## SALPA ANCORA AD ASSE ORIZZONTALE O VERTICALE? SHALL I BUY A HORIZONTAL OR A VERTICAL AXIS WINDLASS?

La scelta di uno o dell'altro modello è legata principalmente allo spazio disponibile sopra e sotto coperta. I salpa ancora orizzontali hanno l'asse di rotazione del barbotin orizzontale e normalmente si trovano totalmente sopra coperta. Sono di conseguenza più ingombranti di un verricello ad asse verticale, il quale è composto da due parti: una sopra coperta, dove è presente il barbotin e l'altra che comprende il moto-riduttore che si trova sotto coperta. Il vantaggio di quest'ultimo modello è di avere uno scarso ingombro sopra coperta ed una maggiore presa della catena, in quanto il barbotin lavora su più maglie contemporaneamente rispetto ad un modello orizzontale.

*The choice of a vertical or a horizontal axis windlass is mostly due to available space in the peak. Horizontal axis windlasses have gypsy rotation axis, that is horizontal and normally are wholly on the deck. They are bulkier than a vertical axis windlass, that is composed by two parts: one on the deck, where the gypsy is located, the other part, which includes the gearmotor, which is within the peak. The advantage of the latter is that it is less bulky on the deck, and it has a better chain grip, as the gypsy works on more links at the same time, compared with a horizontal model winch.*

### REQUISITI D'INSTALLAZIONE INSTALLATION REQUIREMENTS

Una volta verificata la potenza, la presenza dell'alimentazione corretta e gli spazi dimensionali del salpa ancora, non rimane che verificare le dimensioni del gavone. Questo è necessario per verificare la quantità di catena (o cima-catena) che sarà possibile imbarcare e per essere certi che, in caso di verricello verticale, ci sia lo spazio per il gruppo moto-riduttore.

*Once you have checked correct rating, correct power supply and windlass size, you need to verify the bow peak size. This is necessary in order to verify the chain (or rope-chain) you can take onboard and to be sure in case of vertical windlass that there is space for the motor gearbox.*

**Infine la distanza tra il foro di cubia e la catena accumulata non dovrebbe risultare inferiore ai 40 cm (16").**

*Least, but not last, the distance between the hawse hole and the accumulated chain might not be less than 40 cm (16").*

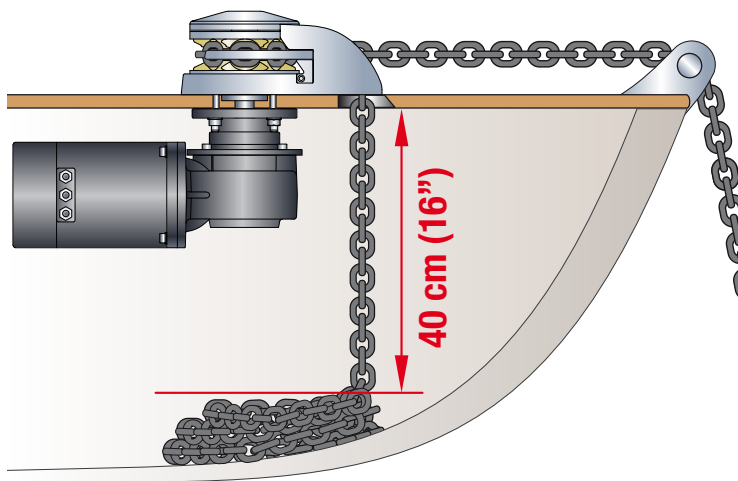

# SIMBOLOGIA SYMBOLOLOGY

**Nel catalogo sono presenti diversi simboli per una veloce identificazione di alcune importanti caratteristiche dei prodotti.**

*In the catalogue you can find different symbols in order to identify quickly some important technical features of our products.*



CIMA CATENA

### SISTEMA TENDI-CIMA

il prodotto supporta l'uso della soluzione cima e catena

#### ROPE-CHAIN SYSTEM

*the product supports the use of rope-chain solution*



CATENA

### SENSORE CONTAMETRI

il prodotto viene fornito già predisposto per la connessione di un contametri

#### CHAINCOUNTER SENSOR

*the product is preset for chaincounter connection*



RELÈ

### RELÈ DI CONTROLLO

il relè di controllo per motori in corrente continua è fornito di serie con il prodotto

#### CONTROL BOX

*control box for DC current is supplied with the windlass*



IDRAULICO

### IDRAULICO

è possibile applicare la motorizzazione idraulica al prodotto

#### HYDRAULIC

*it is possible to supply the windlass with hydraulic motorization*



VOLTS

### TENSIONE 10V A 30V

il prodotto può essere alimentato nel range di tensione indicato senza modificare nulla

#### VOLTAGE 10V TO 30V

*the device can be powered within the indicated range without changing anything*



MOTOR

### COPERTURA MOTORE

Il prodotto è fornito di copertura motore IP67

#### MOTOR COVER

*The product has the IP67 motor cover*

# COPPER GOLD & BLACK

PERCHÈ LIMITARSI  
ALLA QUALITÀ  
QUANDO SI PUÒ AVERE  
ANCHE LO STILE?

*WHY LIMIT YOURSELF TO QUALITY WHEN  
YOU CAN ALSO HAVE STYLE?*

**Nati per soddisfare le richieste più esigenti, da oggi Italwinch ti permette di scegliere il colore del verricello. Su tutta la gamma, infatti, disponiamo di un trattamento innovativo che consente di personalizzare il tuo winch. Disponibili nei colori rame, oro e nero il trattamento PVD è un protettivo molto resistente agli urti e all'acqua salina che viene dato al verricello in acciaio inox 316 tramite l'evaporazione dei metalli che compongono lo strato di rivestimento.**

*Born to satisfy the most demanding requests, from now on Italwinch allows you to choose the color of the winch. In fact, throughout the range, we have an innovative treatment that allows you to customize your winch. Available in copper, gold and black, the PVD treatment is a very resistant to shock and salt water protection that is given to the 316 stainless steel winch by evaporating the metals that make up the coating layer.*

COPPER



**GOLD**

**BLACK**







## IMBARCAZIONI PERSONALIZZATE CUSTOM SOLUTIONS

La grande esperienza ORVEA ereditata, sommata alla professionalità e dinamicità dell'attuale ufficio tecnico, permette di poter seguire il cliente sotto svariati aspetti. Garantiamo un supporto tecnico sul disegno 2D-3D, durante la progettazione della zona di prua ed il posizionamento dei salpa ancora, collaborando anche con il cantiere per il corretto dimensionamento dei prodotti. Capita spesso che su un mega yacht vi siano richieste particolari da parte di armatori, capitani o architetti navali, che possono portare a prodotti personalizzati; seguendo questa idea, siamo in grado di realizzare particolari e prodotti in acciaio inox AISI316, in grado di soddisfare ogni richiesta, rendendo uniche le soluzioni adottate.

*ORVEA experience, added to competence and dynamism of our technical department, enables us to follow the customer needs under every aspect. First of all we guarantee a technical support on 2D-3D drawings during bow planning stage and windlasses positioning, cooperating with the boatyard for the correct products measurement. It happens mostly on mega yachts that the ship owner, or the captain, or naval architects have particular requests that become custom products; following this idea, we can design and carry out AISI316 products, which can satisfy any request, making our solutions unique.*



## IMBARCAZIONI MILITARI E COMMERCIALI MILITARY VESSELS AND COMMERCIAL BOATS

Fin dall'inizio, la società è stata coinvolta nella fornitura di imbarcazioni militari e navi commerciali. Questo tipo di richieste ha consentito Italwinch crescere e sviluppare prodotti studiati per un uso continuativo e intensivo, dimensionando tutte le parti meccaniche per rispettare questi requisiti. Ora l'azienda rispetta le norme di qualità ISO9001 ed i prodotti sono sempre realizzati sottostando alle specifiche delle autorità di certificazione. Per questo motivo, Italwinch supera e soddisfa i requisiti degli enti di classificazione più severi al mondo, tra cui LRS, BV, ABS, CCS, RINA, RRR, RMRS.

*Since the beginning, the company was involved in supplying to military boats and commercial vessels. These kind of requests permitted Italwinch to grow and develop products studied for a continuative and intensive use, dimensioning the mechanical parts of all the range under these requirements. Now the company has gained the quality assurance discipline ISO9001 and 3D products design is always undertaken with classification body requirements. Thanks to this reason, Italwinch exceeds and meets the strictest world's classification requirements, including LRS, BV, ABS, CCS, RINA, RRR, RMRS.*

**VERRICELLI VERTICALI**  
VERTICAL WINDLASSES



# LINEA CL

## CL LINE

La linea CL è la nuova gamma di prodotti Italwinch completamente in acciaio inox AISI 316, per imbarcazioni fino ai 16 metri. Essa è composta da due categorie di prodotti in grado di soddisfare tutte le possibili esigenze dei clienti.

Supportano tutti i principali tipi di catena in commercio ed hanno la possibilità di gestire anche la cima a tre legnoli (cima-catena). La linea CLS è compatta sopra coperta e motorizzabile con tre diverse opzioni fino a 1000W.

La linea CLP è studiata per imbarcazioni oltre i 10 metri, e può raggiungere grandi prestazioni con il motore a 1500W.

*The CL line is the new Italwinch range of products, completely in AISI 316 stainless steel for boats up to 16 meters. It is composed by two categories of products to meet all possible customers' needs.*

*They all support the main kind of chain and have the possibility of managing even a three strands rope (rope-chain). CLS line is compact on the deck and available in three different motor options up to 1000W.*

*The CLP line is designed for boats over 10 meters; it can reach high performances with the powerful 1500W motor.*



**IP67**

MOTOR

**Tutta la gamma CL è fornita con copertura motore IP67**

*All the CL range is supplied with the IP 67 motor cover*



Verricello ad asse verticale in acciaio inox AISI 316. Disponibile nella versione ad alto o basso profilo, con differenti motorizzazioni è suggerito per barche fino ai 13m. Il salpa ancore CLS può usare catena fino a 8mm ed è provvisto del sistema tendicima. Viene fornito con il sensore contametri già integrato.

*Stainless steel AISI 316 vertical windlass. Available in high or low profile, with different drives and recommended for boats up to 13m. CLS can use chains up to 8 mm and is equipped with rope tensioner. Comes with built-in chain counter sensor.*



CIMA CATENA



RELÈ



CATENA



IP67

MOTOR

CARATTERISTICHE	POTENZA MOTORE <i>ELECTRIC MOTOR</i>	500W	500W	700W	700W	1000W	1000W
	TENSIONE DI ALIMENTAZIONE <i>MOTOR SUPPLY VOLTAGE</i>	12V	24V	12V	24V	12V	24V
	TIRO ISTANTANEO MASSIMO <i>MAXIMUM PULL</i>	650 Kg	660 Kg	750 Kg	760 Kg	930 Kg	940 Kg
	CARICO LAVORO AL SOLLEVAMENTO <i>LIFT WORKING LOAD</i>	90 Kg	90 Kg	100 Kg	100 Kg	130 Kg	130 Kg
	VELOCITÀ DI RECUPERO A CARICO <i>LINE SPEED</i>	23 mt/min	23 mt/min	25 mt/min	25 mt/min	26 mt/min	26 mt/min
	ASSORBIMENTO MEDIO <i>CURRENT ABSORPTION</i>	60 A	32 A	90 A	40 A	115 A	60 A
	PESO (SENZA CAMPANA) <i>WEIGHT (WITHOUT DRUM)</i>	9 Kg	9 Kg	9,5 Kg	9,5 Kg	13 Kg	13 Kg
	PESO (CON CAMPANA) <i>WEIGHT (WITH DRUM)</i>	10 Kg	10 Kg	10,5 Kg	10,5 Kg	14,5 Kg	14,5 Kg

CATENA	Barbotin / Gipsy	6mm			7mm				8mm			
	Catena supportata <i>Chain supported</i>	6mm ISO	6mm DIN766	3/16" BBB	7mm ISO	7mm DIN766	1/4" G4	1/4" BBB	8mm ISO	8mm DIN766	5/16" G4	5/16" BBB
	Cima supportata <i>Rope supported</i>	12mm 3-strand			12mm 3-strand / 8-strand				12mm 3-strand			

500	A	B	C	D	E	F	G	H	I	L	M
	90	56	129	18/35	115	231	76	43	82	182	122

700	A	B	C	D	E	F	G	H	I	L	M
	90	56	129	18/35	115	231	76	43	82	182	122

1000	A	B	C	D	E	F	G	H	I	L	M
	90	56	129	18/35	150	250	76	62	114	182	122

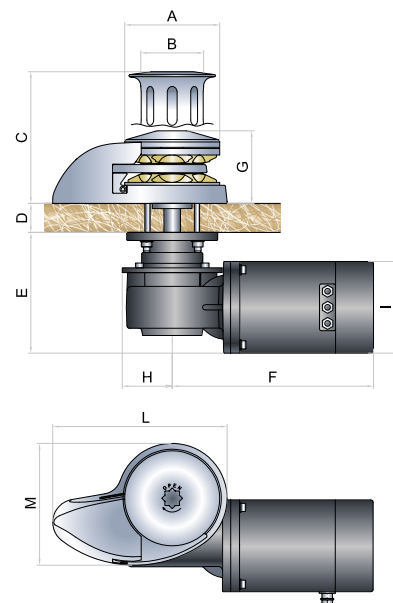

Tutte le misure indicate sono in mm  
All sizes are in mm





Verricello ad asse verticale in acciaio inox AISI 316. Disponibile nella versione ad alto o basso profilo, con differenti motorizzazioni è suggerito per barche fino ai 16m. Il salpa ancora CLP può usare catena da 6mm, 8mm o 10mm ed è provvisto del sistema tendicima. Viene fornito con il sensore contame- tri già integrato.

*CLP is a stainless steel AISI 316 vertical windlass. Available in high or low profile, with different drives and recommended for boats up to 16 m. CLP can use the 6 mm, 8 mm or 10 mm chains and is equipped with rope ten- sioner. Comes with built-in chain counter sensor.*



CARATTERISTICHE	POTENZA MOTORE <i>ELECTRIC MOTOR</i>	700W	700W	1000W	1000W	1500W	1500W
	TENSIONE DI ALIMENTAZIONE <i>MOTOR SUPPLY VOLTAGE</i>	12V	24V	12V	24V	12V	24V
	TIRO ISTANTANEO MASSIMO <i>MAXIMUM PULL</i>	750 Kg	790 Kg	1020 Kg	1060 Kg	1250 Kg	1290 Kg
	CARICO LAVORO AL SOLLEVAMENTO <i>LIFT WORKING LOAD</i>	100 kg	110 kg	130 kg	140 Kg	150 Kg	160 Kg
	VELOCITÀ DI RECUPERO A CARICO <i>LINE SPEED</i>	25 mt/min	25 mt/min	25 mt/min	25 mt/min	26 mt/min	26 mt/min
	ASSORBIMENTO MEDIO <i>CURRENT ABSORPTION</i>	90 A	40 A	115 A	60 A	130 A	70 A
	PESO (SENZA CAMPANA) <i>WEIGHT (WITHOUT DRUM)</i>	13,7 Kg	13,7 Kg	16,7 Kg	16,7 Kg	16,9 Kg	16,9 Kg
	PESO (CON CAMPANA) <i>WEIGHT (WITH DRUM)</i>	N/A	N/A	18,1 Kg	18,1 Kg	18,3 Kg	18,3 Kg

CATENA	Barbotin / Gipsy	6mm		8mm				10mm		10 DIN 766	
	Catena supportata <i>Chain supported</i>	6mm ISO	6mm DIN766	8mm ISO	8mm DIN766	5/16" G4	5/16" BBB	10mm ISO	3/8" G4	10mm DIN766	3/8" BBB
	Cima supportata <i>Rope supported</i>	N/A		14mm - 3-strand				N/A		N/A	

700	A	B	C	D	E	F	G	H	I	L	M
	118	78	164	18/35	150	231	92	43	82	221	156

1000	A	B	C	D	E	F	G	H	I	L	M
	118	78	164	25/50	150	250	92	62	114	221	156

1500	A	B	C	D	E	F	G	H	I	L	M
	118	78	164	25/50	150	250	92	62	114	221	156

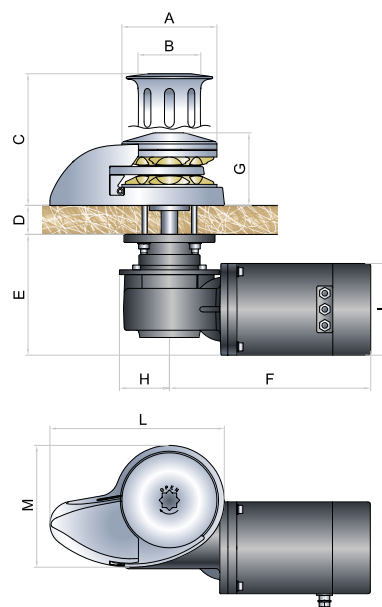

Tutte le misure indicate sono in mm  
All sizes are in mm



Verricello ad asse verticale in acciaio inox AISI 316 con riduttore epicicloidale. Disponibile nella versione basso profilo, con differenti motorizzazioni è suggerito per barche fino ai 10m. Il salpa ancore CS-V può usare catena fino a 8mm. Tutti i modelli sono provvisti di sistema tendicima. Viene fornito con il sensore contametri già integrato.

*CS-V is a stainless steel AISI 316 vertical windlass with planetary drive. Available low profile, with different drives and recommended for boats up to 10m. CS-V can use chains up to 8 mm and is equipped with rope tensioner. Comes with built-in chain counter sensor.*



CARATTERISTICHE	POTENZA MOTORE <i>ELECTRIC MOTOR</i>	500W	500W	800W	800W
	TENSIONE DI ALIMENTAZIONE <i>MOTOR SUPPLY VOLTAGE</i>	12V	24V	12V	24V
	TIRO ISTANTANEO MASSIMO <i>MAXIMUM PULL</i>	670 Kg	680 Kg	800 Kg	810 Kg
	CARICO LAVORO AL SOLLEVAMENTO <i>LIFT WORKING LOAD</i>	90 Kg	90 Kg	100 Kg	100 Kg
	VELOCITÀ DI RECUPERO A CARICO <i>LINE SPEED</i>	23 mt/min	23 mt/min	25 mt/min	25 mt/min
	ASSORBIMENTO MEDIO <i>CURRENT ABSORPTION</i>	60 A	32 A	90 A	45 A
PESO (SENZA CAMPANA) <i>WEIGHT (WITHOUT DRUM)</i>	10 Kg	10 Kg	10,5 Kg	10,5 Kg	

CATENA	Barbotin / Gipsy	6mm			7mm				8mm			
	Catena supportata <i>Chain supported</i>	6mm ISO	6mm DIN766	3/16" BBB	7mm ISO	7mm DIN766	1/4" G4	1/4" BBB	8mm ISO	8mm DIN766	5/16" G4	5/16" BBB
	Cima supportata <i>Rope supported</i>	12mm 3-strand			12mm 3-strand / 8-strand				12mm 3-strand			

500	A	B	C	D	E	F	G
	90	78	18/40	236	90	191	143

800	A	B	C	D	E	F	G
	90	78	18/40	236	90	191	143

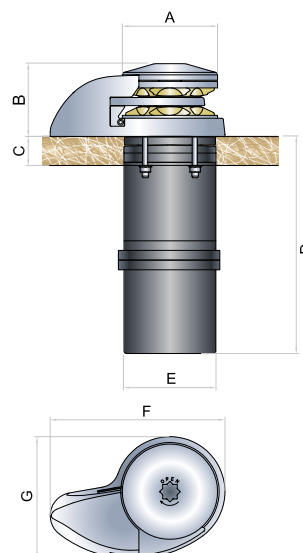

Tutte le misure indicate sono in mm  
All sizes are in mm

# SMART ROUND-R1

VERTICAL WINDLASSES

Verricello ad asse verticale con base in alluminio e campana in acciaio inox AISI 316. Disponibile nella versione ad alto o basso profilo, con differenti motorizzazioni è suggerito per barche fino ai 13m. Il salpa ancora SMART-R1 può usare catena fino a 8mm. Viene fornito con il sensore contametri già integrato.

*Alluminium base and Stainless steel AISI 316 drums vertical windlass. Available in high or low profile, with different drives and recommended for boats up to 13m. SMART-R1 can use chains up to 8 mm. Comes with built-in chain counter sensor.*



**OPTIONAL**  
STAFFA DI MONTAGGIO  
MOUNTING BRACKET



RELE



CATENA



IP67

MOTOR

CARATTERISTICHE	POTENZA MOTORE <i>ELECTRIC MOTOR</i>	500W	500W	700W	700W	1000W	1000W
	TENSIONE DI ALIMENTAZIONE <i>MOTOR SUPPLY VOLTAGE</i>	12V	24V	12V	24V	12V	24V
	TIRO ISTANTANEO MASSIMO <i>MAXIMUM PULL</i>	650 Kg	660 Kg	750 Kg	760 Kg	930 Kg	940 Kg
	CARICO LAVORO AL SOLLEVAMENTO <i>LIFT WORKING LOAD</i>	90 Kg	90 Kg	100 Kg	100 Kg	130 Kg	130 Kg
	VELOCITÀ DI RECUPERO A CARICO <i>LINE SPEED</i>	23 mt/min	23 mt/min	25 mt/min	25 mt/min	26 mt/min	26 mt/min
	ASSORBIMENTO MEDIO <i>CURRENT ABSORPTION</i>	60 A	32 A	90 A	40 A	115 A	60 A
	PESO (SENZA CAMPANA) <i>WEIGHT (WITHOUT DRUM)</i>	8 Kg	8 Kg	8,5 Kg	8,5 Kg	13,6 Kg	13,6 Kg
	PESO (CON CAMPANA) <i>WEIGHT (WITH DRUM)</i>	9 Kg	9 Kg	9,5 Kg	9,5 Kg	14,5 Kg	14,5 Kg

CATENA	Barbotin / Gipsy	6mm			7mm				8mm			
	Catena supportata <i>Chain supported</i>	6mm ISO	6mm DIN766	3/16" BBB	7mm ISO	7mm DIN766	1/4" G4	1/4" BBB	8mm ISO	8mm DIN766	5/16" G4	5/16" BBB

500	A	B	C	D	E	F	G	H	I	L
	110	56	133	18/35	111	231	80	43	82	110

700	A	B	C	D	E	F	G	H	I	L
	110	56	133	18/35	111	231	80	43	82	110

1000	A	B	C	D	E	F	G	H	I	L
	110	56	133	18/35	150	250	80	62	114	110

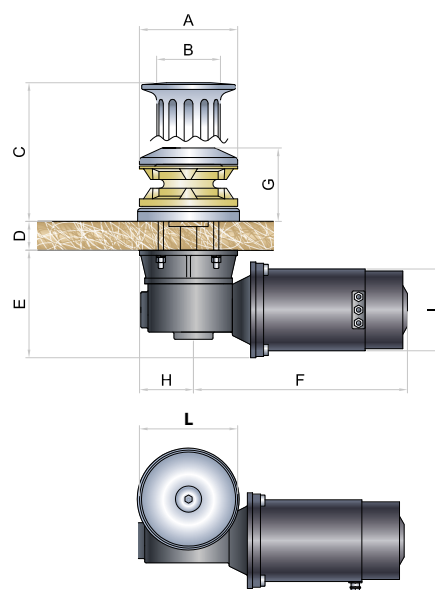

Tutte le misure indicate sono in mm  
All sizes are in mm



Verricello ad asse verticale in acciaio inox AISI 316. Disponibile nella versione ad alto o basso profilo, con differenti motorizzazioni è suggerito per barche fino ai 16m. Il salpa ancora SMART-R3 può usare catena da 6mm, 8mm o 10mm. Viene fornito con il sensore contametri già integrato.

*Stainless steel AISI 316 vertical windlass. Available in high or low profile, with different drives and recommended for boats up to 16 m. SMART-R3 can use the 6 mm, 8 mm or 10 mm chains. Comes with built-in chain counter sensor.*



**OPTIONAL**  
STAFFA DI MONTAGGIO  
MOUNTING BRACKET



RELÈ



CATENA

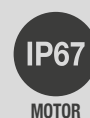

IP67  
MOTOR

CARATTERISTICHE	POTENZA MOTORE <i>ELECTRIC MOTOR</i>	700W	1000W	1000W	1500W	1500W
	TENSIONE DI ALIMENTAZIONE <i>MOTOR SUPPLY VOLTAGE</i>	12V	12V	24V	12V	24V
	TIRO ISTANTANEO MASSIMO <i>MAXIMUM PULL</i>	750 Kg	1020 Kg	1060 Kg	1250 Kg	1290 Kg
	CARICO LAVORO AL SOLLEVAMENTO <i>LIFT WORKING LOAD</i>	100 kg	130 kg	140 Kg	150 Kg	160 Kg
	VELOCITÀ DI RECUPERO A CARICO <i>LINE SPEED</i>	25 mt/min	25 mt/min	25 mt/min	26 mt/min	26 mt/min
	ASSORBIMENTO MEDIO <i>CURRENT ABSORPTION</i>	90 A	115 A	60 A	130 A	70 A
	PESO (SENZA CAMPANA) <i>WEIGHT (WITHOUT DRUM)</i>	13,7 Kg	16,7 Kg	16,7 Kg	16,9 Kg	16,9 Kg
	PESO (CON CAMPANA) <i>WEIGHT (WITH DRUM)</i>	N/A	18,1 Kg	18,1 Kg	18,3 Kg	18,3 Kg

CATENA	Barbotin / Gipsy	6mm		8mm			10mm		10 DIN 766	
	Catena supportata <i>Chain supported</i>	6mm ISO	6mm DIN766	8mm ISO	8mm DIN766	5/16" G4	5/16" BBB	10mm ISO	3/8" G4	10mm DIN766

700	A	B	C	D	E	F	G	H	I	L
		130	78	172	18/30	150	221	98	43	82

1000	A	B	C	D	E	F	G	H	I	L
		130	78	172	30/52	150	250	98	62	114

1500	A	B	C	D	E	F	G	H	I	L
		130	78	172	30/52	150	250	98	62	114

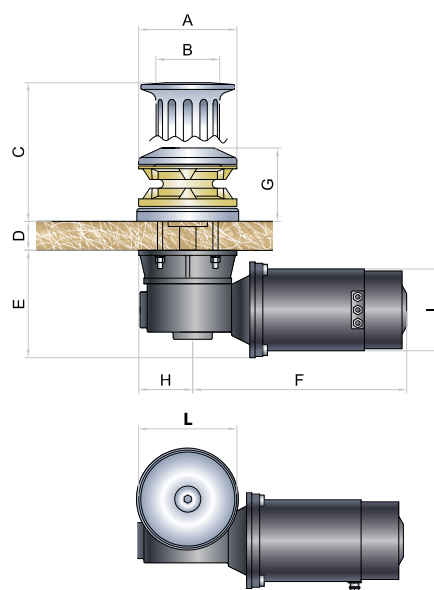

Tutte le misure indicate sono in mm  
All sizes are in mm

Verricello ad asse verticale in acciaio inox AISI 316. Disponibile nella versione ad alto o basso profilo, con differenti motorizzazioni è suggerito per barche fino ai 19m. Lo STAR può usare catena da 10 mm a 12 mm e viene fornito con il sensore contametri già integrato. Possibilità di avere la motorizzazione a 12V, 24V 230v, 400v o idraulica.

STAR is a stainless steel AISI 316 vertical windlass. Available in high or low profile, with different drives and recommended for boats up to 19m. STAR can use chains from 10 mm to 12 mm and comes with built-in chain counter sensor. Possibility of 12V, 24V, 230V, 400V or hydraulic drive.



CARATTERISTICHE	POTENZA MOTORE <i>ELECTRIC MOTOR</i>	1500W	1500W	1700W	1700W	2000W	HY	2000W	
	TENSIONE DI ALIMENTAZIONE <i>MOTOR SUPPLY VOLTAGE</i>	12V	24V	12V	24V	24V	N/A	230V/400V	
	TIRO ISTANTANEO MASSIMO <i>MAXIMUM PULL</i>	1250 Kg	1290 Kg	1650 Kg	1700 Kg	1750 Kg	380 Kg	1700 Kg	
	CARICO LAVORO AL SOLLEVAMENTO <i>LIFT WORKING LOAD</i>	170 Kg	180 Kg	240 Kg	250 Kg	270 Kg	380 Kg	250 Kg	
	VELOCITÀ DI RECUPERO A CARICO <i>LINE SPEED</i>	12 mt/min	12 mt/min	12 mt/min	12 mt/min	12 mt/min	12 mt/min	12 mt/min	
	ASSORBIMENTO MEDIO <i>CURRENT ABSORPTION</i>	130 A	70 A	138 A	75 A	100A	N/A	N/A	
	PESO (SENZA CAMPANA) <i>WEIGHT (WITHOUT DRUM)</i>	←			30 to 35 Kg		→		
	PESO (CON CAMPANA) <i>WEIGHT (WITH DRUM)</i>	←			35 to 40 Kg		→		

CATENA	Barbotin / Gipsy	8mm				10mm		10 DIN 766		12mm	13mm	1/2" HT
	Catena supportata <i>Chain supported</i>	8mm ISO	8mm DIN766	5/16" G4	5/16" BBB	10mm ISO	3/8" G4	10mm DIN 766	3/8" BBB	12mm ISO	13mm DIN766	1/2" HT
	Cima supportata <i>Rope supported</i>	N/A				N/A		N/A		N/A	N/A	N/A

1500	A	B	C	D	E	F	G	H	I
	150	102	212	37/62	150	250	112	62	114

1700	A	B	C	D	E	F	G	H	I
	150	102	212	37/62	165	330	112	85	125

2000-DC	A	B	C	D	E	F	G	H	I
	150	102	212	37/62	165	335	112	85	125

HY	A	B	C	D	E	F	G	H	I
	150	102	212	37/62	165	227	112	85	170

2000-AC	A	B	C	D	E	F	G	H	I
	150	102	212	37/62	210	350	112	85	165

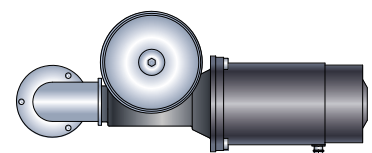
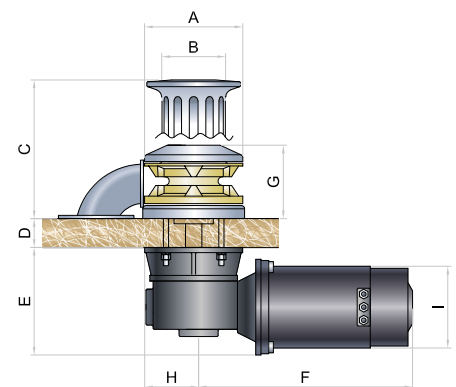

Tutte le misure indicate sono in mm  
All sizes are in mm

Orchid è un verricello ad asse verticale completamente in acciaio inox AISI 316. Disponibile nella versione ad alto o basso profilo, con differenti motorizzazioni, è suggerito per imbarcazioni fino ai 22 metri. Orchid può usare catene da 8 mm, 10mm e 12 mm e viene fornito con il sensore contametri già integrato. Possibilità di avere motorizzazioni da 12V, 24V, 230V, 400V o idraulica. Rope-chain system per catena da 12mm compatibile con cima a 3 legnoli da 18mm e da 19mm.

*Orchid is a stainless steel AISI vertical windlass. Available in high or low profile version, with different motorizations, it is suggested for boats up to 22 meters. Orchid can bring 8mm, 10mm and 12mm chains and comes with built-in chain counter sensor. Possibility of 12V, 24V, 230V, 400V or hydraulic motorizations. Rope-chain system for 12mm chain compatible with 3-strand 18mm or 19 mm rope.*



CARATTERISTICHE	POTENZA MOTORE <i>ELECTRIC MOTOR</i>	1500W	1500W	1700W	1700W	2000W	2000W	2300W	2200W	HY1	HY2
	TENSIONE DI ALIMENTAZIONE <i>MOTOR SUPPLY VOLTAGE</i>	12V	24V	12V	24V	24V	230/400V	24V	230/400V	N/A	N/A
	TIRO ISTANTANEO MASSIMO <i>MAXIMUM PULL</i>	1250Kg	1290Kg	1650Kg	1700Kg	1750Kg	1700Kg	2200Kg	2550Kg	380Kg	1500Kg
	CARICO LAVORO AL SOLLEVAMENTO <i>LIFT WORKING LOAD</i>	170Kg	180Kg	240Kg	250Kg	270Kg	300Kg	500Kg	535Kg	380Kg	1500Kg
	VELOCITÀ DI RECUPERO A CARICO <i>LINE SPEED</i>	12mt/min	12mt/min	12mt/min	12mt/min	12mt/min	20mt/min	12mt/min	17mt/min	12mt/min	12mt/min
	ASSORBIMENTO MEDIO <i>CURRENT ABSORPTION</i>	130A	70A	138A	75A	100A	N/A	120A	N/A	N/A	N/A
	PESO (SENZA CAMPANA) <i>WEIGHT (WITHOUT DRUM)</i>	← 25 to 35 Kg →									
	PESO (CON CAMPANA) <i>WEIGHT (WITH DRUM)</i>	← 30 to 40 Kg →									

CATENA	Barbotin / Gipsy	8mm				10mm		10 DIN 766		12mm	13mm	1/2" HT
	Catena supportata <i>Chain supported</i>	8mm ISO	8mm DIN766	5/16" G4	5/16" BBB	10mm ISO	3/8" G4	10mm DIN 766	3/8" BBB	12mm ISO	13mm DIN766	1/2" HT
	Cima supportata <i>Rope supported</i>	N/A				N/A		N/A		18mm - 19mm - 20mm 3 strand	N/A	N/A

1500	A	B	C	D	E	F	G	H	I	L
	150	102	212	37-62	141	150	107	72	268	188

1700 2000	A	B	C	D	E	F	G	H	I	L
	150	102	212	37-62	174	330	107	78	268	188

2300	A	B	C	D	E	F	G	H	I	L
	150	102	212	37-64	190	439	107	100	268	188

2200AC	A	B	C	D	E	F	G	H	I	L
	150	102	212	37-62	174	454	107	100	268	188

HY1	A	B	C	D	E	F	G	H	I	L
	150	102	212	37-62	165	227	107	78	268	188

HY2	A	B	C	D	E	F	G	H	I	L
	150	102	212	37-62	174	232	107	100	268	188

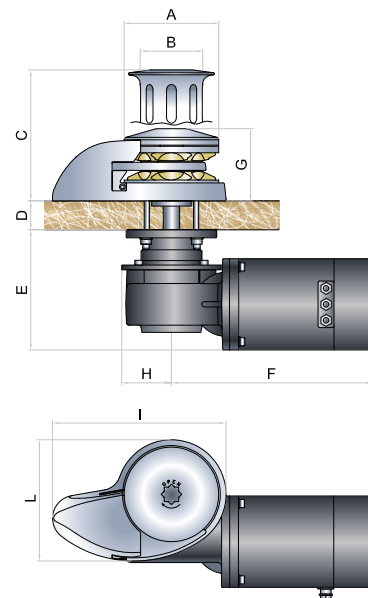

Tutte le misure indicate sono in mm  
All sizes are in mm





Verricello ad asse verticale in acciaio inox AISI 316. Disponibile nella versione ad alto o basso profilo, con differenti motorizzazioni è suggerito per barche fino ai 26m. Lo STAR PLUS può usare catene fino a 14 mm e viene fornito con il sensore contametri già integrato. Possibilità di avere la motorizzazione a 24v, 230v, 400v o idraulica.

STAR PLUS is a stainless steel AISI 316 vertical windlass. Available in high or low profile, with different drives and recommended for boats up to 26m. STAR PLUS can use chains up to 14 mm and comes with built-in chain counter sensor. Possibility of 24V, 230V, 400V or hydraulic drive.



CARATTERISTICHE	POTENZA MOTORE <i>ELECTRIC MOTOR</i>	2300W	2700W	3000W	2200W	3600W	HY
	TENSIONE DI ALIMENTAZIONE <i>MOTOR SUPPLY VOLTAGE</i>	24V	24V	24V	230V/400V	230V/400V	N/A
	TIRO ISTANTANEO MASSIMO <i>MAXIMUM PULL</i>	2200 Kg	2300 Kg	2700 Kg	2550 Kg	2600 Kg	1500 Kg
	CARICO LAVORO AL SOLLEVAMENTO <i>LIFT WORKING LOAD</i>	500 Kg	600 Kg	850 Kg	730 Kg	824 Kg	1500 Kg
	VELOCITÀ DI RECUPERO A CARICO <i>LINE SPEED</i>	12 mt/min	12 mt/min	12 mt/min	12 mt/min	12 mt/min	12 mt/min
	ASSORBIMENTO MEDIO <i>CURRENT ABSORPTION</i>	120 A	150 A	180 A	N/A	N/A	N/A
	PESO (SENZA CAMPANA) <i>WEIGHT (WITHOUT DRUM)</i>	←			50 to 80 Kg	→	
	PESO (CON CAMPANA) <i>WEIGHT (WITH DRUM)</i>	←			60 to 90 Kg	→	

CATENA	Barbotin / Gipsy	10mm		10 DIN 766		12mm			14mm	1/2" HT	14 C.T.	12,5 C.T.
	Catena supportata <i>Chain supported</i>		10mm ISO4565	3/8" G4	10mm DIN766	3/8" BBB	12mm ISO4565	13mm DIN 766	7/16" G4	14mm ISO4565	1/2" HT	14 Stud link

2300	A	B	C	D	E	F	G	H
	225	125	281	60-110	190	439	154	100

2700	A	B	C	D	E	F	G	H
	225	125	281	60-110	190	439	154	100

3000	A	B	C	D	E	F	G	H
	225	125	281	60-110	260	454	154	130

2200AC	A	B	C	D	E	F	G	H
	225	125	281	60-110	190	454	154	100

3600AC	A	B	C	D	E	F	G	H
	225	125	281	60-110	190	433	154	100

HY	A	B	C	D	E	F	G	H
	225	125	281	60-110	190	232	154	100

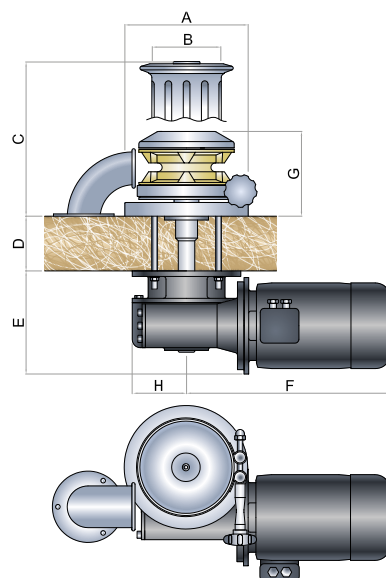

Tutte le misure indicate sono in mm  
All sizes are in mm



Verricello ad asse verticale in acciaio inox AISI 316. Disponibile nella versione ad alto o basso profilo, con differenti motorizzazioni è suggerito per barche fino ai 30m. Il salpa ancore MOON può usare catena fino a 16 mm. Tutti i modelli per catene con traversino supportano le maglie kenter. Possibilità di avere la motorizzazione a 24V, 230V, 400V o idraulica.

MOON is a stainless steel AISI 316 vertical windlass. Available in high or low profile, with different drives and recommended for boats up to 30m. MOON can use chains up to 16 mm. All the models for stud link chains support kenter link. Possibility of 24V, 230V, 400V or hydraulic drive.



CARATTERISTICHE	POTENZA MOTORE <i>ELECTRIC MOTOR</i>	3000W	4000W	HY
	TENSIONE DI ALIMENTAZIONE <i>MOTOR SUPPLY VOLTAGE</i>	24V	230V/400V	N/A
	TIRO ISTANTANEO MASSIMO <i>MAXIMUM PULL</i>	3100 Kg	3500 Kg	1900 Kg
	CARICO LAVORO AL SOLLEVAMENTO <i>LIFT WORKING LOAD</i>	1000 Kg	1250 Kg	1900 Kg
	VELOCITÀ DI RECUPERO A CARICO <i>LINE SPEED</i>	15 mt/min	14 mt/min	14 mt/min
	ASSORBIMENTO MEDIO <i>CURRENT ABSORPTION</i>	180 A	N/A	N/A
	PESO (SENZA CAMPANA) <i>WEIGHT (WITHOUT DRUM)</i>	←	N/A	→
	PESO (CON CAMPANA) <i>WEIGHT (WITH DRUM)</i>	←	70 to 100 Kg	→

CATENA	Barbotin / Gipsy	12mm			13DIN764	12,5 C.T.	14mm	1/2" HT	14 C.T.	16mm	16DIN766
	Catena supportata <i>Chain supported</i>		12mm ISO4565	13mm DIN 766	7/16" G4	13mm DIN764	12,5 Stud link	14mm ISO4565	1/2" HT	14 Stud link	16mm ISO

3000	A	B	C	D	E	F	G	H
	225	215	140	347	70/120	238	454	183

4000AC	A	B	C	D	E	F	G	H
	225	215	140	347	70/120	260	525	183

HY	A	B	C	D	E	F	G	H
	225	215	140	347	70/120	260	285	183

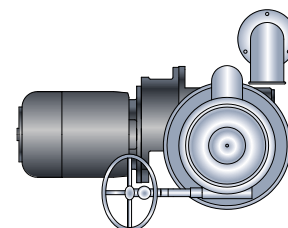
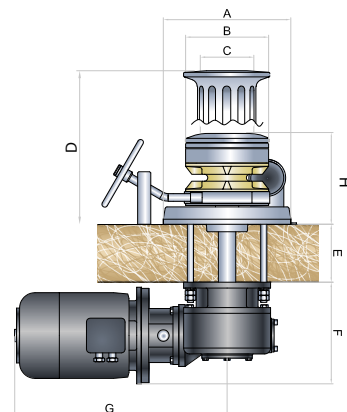

Tutte le misure indicate sono in mm  
All sizes are in mm

ARADO è un verricello ad asse verticale in acciaio inox AISI 316. Disponibile con differenti motorizzazioni è suggerito per imbarcazioni fino ai 50 metri. L'ARADO può usare catena fino a 20,5 mm con traversino di diametro. Tutti i modelli per catene con traversino supportano le maglie kenter. Possibilità di avere la motorizzazione a 230V, 400V o idraulica.

ARADO is a stainless steel AISI 316 vertical windlass. Available with different motorization it's suggested for boats up to 50 meters. The ARADO can bring chain up to 20,5 mm with stud link size. All the models for stud link chains support kenter link. Possibility to have different motor supply: 230V, 400V or hydraulic.



IDRAULICO

CARATTERISTICHE	POTENZA MOTORE <i>ELECTRIC MOTOR</i>	4000W	5500W	HY1
	TENSIONE DI ALIMENTAZIONE <i>MOTOR SUPPLY VOLTAGE</i>	230V/400V	230V/400V	N/A
	CARICO LAVORO MASSIMO ISTANTANEO <i>MAXIMUM LIFT LOAD</i>	3980 Kg	5060 Kg	4000 Kg
	CARICO LAVORO AL SOLLEVAMENTO <i>LIFT WORKING LOAD</i>	1990 Kg	2530 Kg	4000 Kg
	VELOCITÀ DI RECUPERO A CARICO <i>LINE SPEED</i>	12 mt/min	12 mt/min	12 mt/min
	ASSORBIMENTO MEDIO <i>CURRENT ABSORPTION</i>	N/A	N/A	N/A
	PESO (CON CAMPANA) <i>WEIGHT (WITH DRUM)</i>	← 250 to 295 Kg →		

CATENA	Barbotin / Gipsy	16 C.T.	17,5 C.T.	19 C.T.	20,5 C.T.
	Catena supportata <i>Chain supported</i>		16 Stud link	17,5 Stud link	19 Stud link

5500AC	A	B	C	D	E	F	G
	350	315	214	537	50-150	555	656

7500AC	A	B	C	D	E	F	G
	350	315	214	537	50-150	555	656

9200AC	A	B	C	D	E	F	G
	380	340	214	537	50-150	606	735

HY	A	B	C	D	E	F	G
	350	340	215	537	50-150	555	350

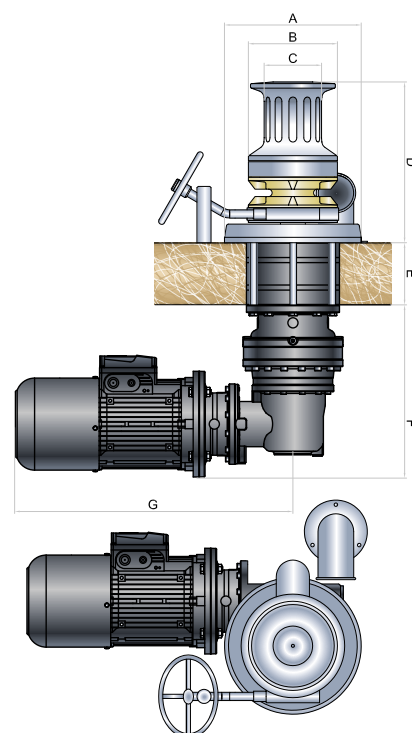

Tutte le misure indicate sono in mm  
All sizes are in mm



OPTIONAL



**CASSETTA CONTROLLO  
INVERTER**  
CONTROL PANEL/INVERTER



**VOLANTINO CON SNODO  
Ø 280mm**  
REMOTE BAND BRAKE CONTROL  
Ø 280mm



**PASSACATENA CON RULLO**  
CHAIN PIPE ROLLER



**PASSACATENA  
PERSONALIZZATO**  
CUSTOM CHAIN PIPE

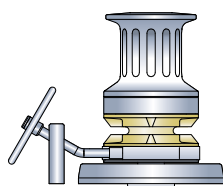

**Configurazione ortogonale**  
*Orthogonal configuration*

**Configurazione coassiale**  
*Coaxial configuration*

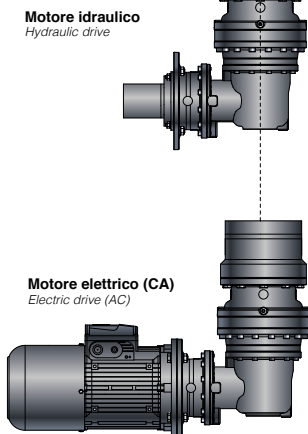

**Motore idraulico**  
*Hydraulic drive*

**Motore elettrico (CA)**  
*Electric drive (AC)*

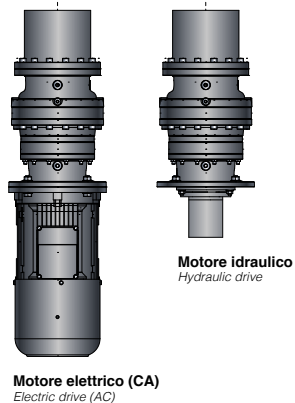

**Motore idraulico**  
*Hydraulic drive*

**Motore elettrico (CA)**  
*Electric drive (AC)*





# LINEA NV

## THE NV LINE

La linea di verricelli NV è il frutto di oltre mezzo secolo di esperienza della Officina Navale Nanni. I prodotti sono forniti con motoriduttori epicicloidali, dimensionati per uso continuativo e sono provvisti di motore in corrente alternata, con freno elettromagnetico di serie. Possono anche avere motorizzazioni idraulica o pneumatica. La caratteristica di questa gamma, è la massima personalizzazione in base alle richieste del cantiere; per questo motivo, tutti i dati segnalati sono riassuntivi delle molteplici varianti possibili e possono subire variazioni in base alla configurazione che si vuole ottenere.

*NV windlass range comes from more than half a century of experience made by Officina Navale Nanni. The products are supplied with epicycloidal motor-gearboxes, made for continuous use and standard models are provided with AC motor with electro-magnetic brake. They can even be supplied with hydraulic or pneumatic motors. The most important characteristic is the possibility of custom solutions, according to the shipyard requests; that's why all technical features are recapitulatory of the possible versions and can change according to the configuration you want to obtain.*

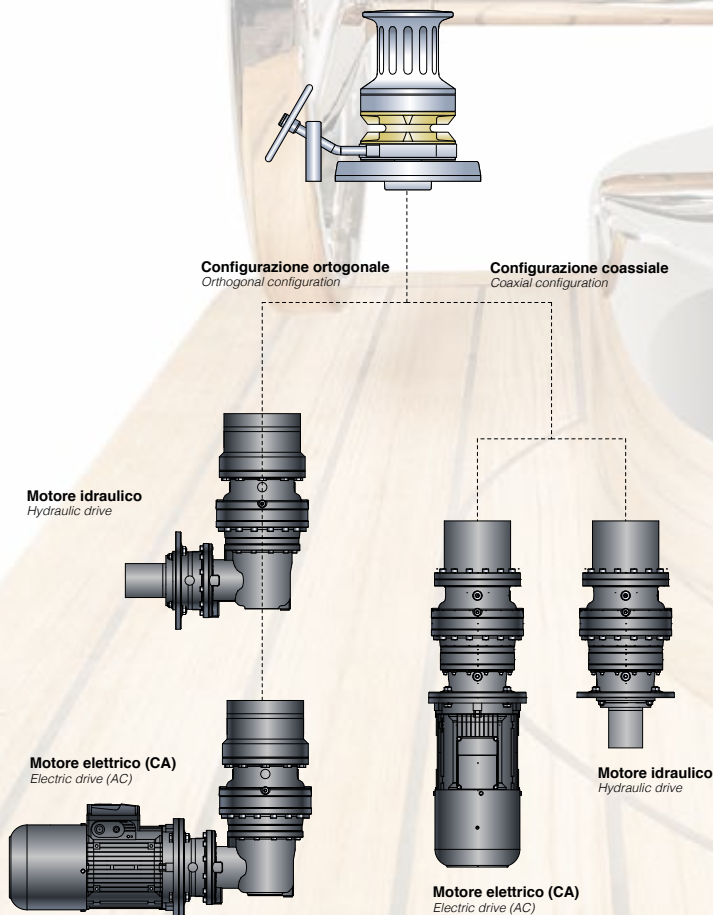



**NV 16B** è un verricello ad asse verticale in acciaio inox AISI 316. Disponibile in versione sia elettrica che idraulica è suggerito per imbarcazioni fino ai 42 metri. E' in grado di supportare catene da 12mm a 16 mm con traversino. Il freno elettromagnetico e l'innesto a denti delle frizioni sono di serie.

**NV 16B** is a stainless steel AISI 316 vertical windlass. Available in electric and hydraulic versions, it is suggested for boats up to 42 meters. It can bring chains from 12mm to 16mm with stud link. The electromagnetic brake and dog clutches instead conical clutches are standard.



TYPE APPROVAL



IDRAULICO

CARATTERISTICHE

POTENZA MOTORE <i>ELECTRIC MOTOR</i>	3500W	3000W	4000W	HY
TENSIONE DI ALIMENTAZIONE <i>MOTOR SUPPLY VOLTAGE</i>	24V	230V/400V	230V/400V	N/A
TIRO ISTANTANEO MASSIMO <i>MAXIMUM PULL</i>	3000 Kg	5000 Kg	6700 Kg	3000 Kg
CARICO LAVORO AL SOLLEVAMENTO <i>LIFT WORKING LOAD</i>	1100 Kg	1250 Kg	1700 Kg	3000 Kg
VELOCITÀ DI RECUPERO A CARICO <i>LINE SPEED</i>	13 mt/min	12 mt/min	12 mt/min	12 mt/min
PESO (CON CAMPANA) <i>WEIGHT (WITH DRUM)</i>	←————— 170 to 220 Kg —————→			

CATENA	Barbotin / Gipsy	12mm			1/2" HT	13DIN764	14mm	16mm	16DIN766	12,5 C.T.	14 C.T.	16 C.T.
Catena supportata <i>Chain supported</i>		12mm ISO	13mm DIN 766	7/16" G4	1/2" HT	13mm DIN764	14mm ISO	16mm ISO	16mm DIN766	12,5 Stud link	14 Stud link	16 Stud link

3500	A	B	C	D	E	F	G	H
	330	250	155	400	110/170	263	564	246

3000	A	B	C	D	E	F	G	H
	330	250	155	400	max150	340	626	246

4000	A	B	C	D	E	F	G	H
	330	250	155	400	max150	340	726	246

HY	A	B	C	D	E	F	G	H
	330	250	155	400	max150	340	365	246

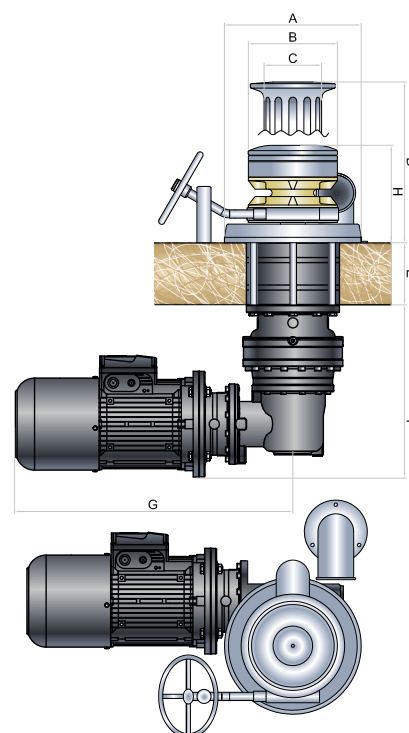

Tutte le misure indicate sono in mm  
All sizes are in mm

Verricelli ad asse verticale modelli NV-19, NV-20, totalmente in acciaio inox AISI 316. Disponibili con differenti motorizzazioni sono suggeriti per imbarcazioni fino a 60m. Tutti i modelli per catene con traversino supportano le maglie kenter. Possibilità di avere la motorizzazione a 230V, 400V o idraulica.

*Vertical windlasses models NV-19, NV-20, are all in stainless steel AISI 316. Available with different drives and recommended for boats up to 60m. All the models for stud link chains support kenter link. Possibility of 230V, 400V or hydraulic drive.*



CARATTERISTICHE	POTENZA MOTORE <i>ELECTRIC MOTOR</i>	4000W	5500W	HY2
	TENSIONE DI ALIMENTAZIONE <i>MOTOR SUPPLY VOLTAGE</i>	230V/400V	230V/400V	N/A
	TIRO ISTANTANEO MASSIMO <i>MAXIMUM PULL</i>	3980 Kg	5025 Kg	4000 Kg
	CARICO LAVORO AL SOLLEVAMENTO <i>LIFT WORKING LOAD</i>	1990 Kg	2500 Kg	4000 Kg
	VELOCITÀ DI RECUPERO A CARICO <i>LINE SPEED</i>	11 mt/min	12 mt/min	12 mt/min

CATENA	Modello Verricello <i>Windlass Model</i>	NV-19			NV-20	
	Barbotin / <i>Gipsy</i>	16 C.T.	17,5 C.T.	19 C.T.	20,5 C.T.	
	Catena supportata <i>Chain supported</i>	16 Stud link	17,5 Stud link	19 Stud link	20,5 Stud link	

4000	A	B	C	D	E	F	G
	400	315	208	598	MIN180	426	657
5500	A	B	C	D	E	F	G
	400	315	208	598	MIN180	426	657
7500	A	B	C	D	E	F	G
	400	315	208	598	MIN180	512	770
9200	A	B	C	D	E	F	G
	500	392	300	598	MIN240	492	830
HY1	A	B	C	D	E	F	G
	400	315	208	598	MIN180	512	350
HY2	A	B	C	D	E	F	G
	400	315	208	598	MIN180	792	476

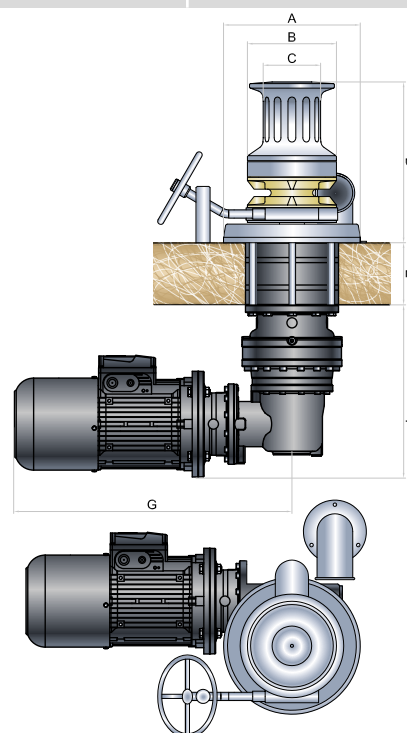

Tutte le misure indicate sono in mm  
All sizes are in mm



Verricelli ad asse verticale modelli NV-24, totalmente in acciaio inox AISI 316. Disponibili con differenti motorizzazioni sono suggeriti per imbarcazioni fino a 65m. Tutti i modelli per catene con traversino supportano le maglie kenter. Possibilità di avere la motorizzazione a 230V, 400V o idraulica.

Vertical windlasses models NV-24 are all in stainless steel AISI 316. Available with different drives and recommended for boats up to 65m. All the models for stud link chains support kenter link. Possibility of 230V, 400V or hydraulic drive.



IDRAULICO

CARATTERISTICHE	POTENZA MOTORE <i>ELECTRIC MOTOR</i>	9200W	11000W	HY
	TENSIONE DI ALIMENTAZIONE <i>MOTOR SUPPLY VOLTAGE</i>	230V/400V	230V/400V	N/A
	TIRO ISTANTANEO MASSIMO <i>MAXIMUM PULL</i>	8400 Kg	9200 Kg	4500 Kg
	CARICO LAVORO AL SOLLEVAMENTO <i>LIFT WORKING LOAD</i>	4180 Kg	4600 Kg	4500 Kg
	VELOCITÀ DI RECUPERO A CARICO <i>LINE SPEED</i>	12 mt/min	13 mt/min	12 mt/min

CATENA	Modello Verricello <i>Windlass Model</i>	NV-24	
	Barbotin / <i>Gipsy</i>	22 C.T.	24 C.T.
	Catena supportata <i>Chain supported</i>	22 Stud link	24 Stud link

9200	A	B	C	D	E	F	G
	500	400	300	515	MIN240	492	830

11000	A	B	C	D	E	F	G
	500	400	300	515	MIN240	492	830

HY	A	B	C	D	E	F	G
	500	400	300	515	MIN240	492	476

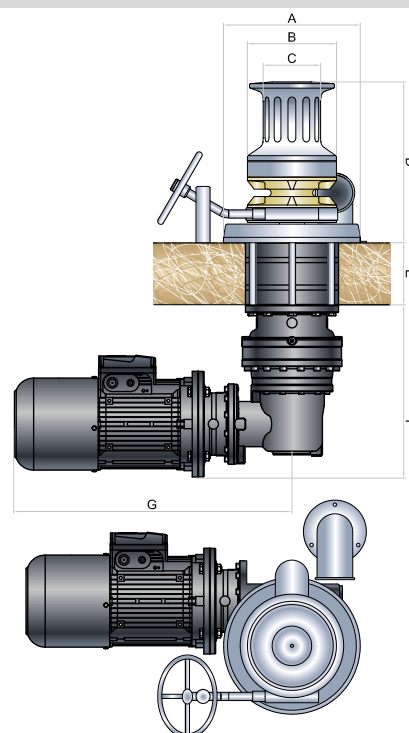

Tutte le misure indicate sono in mm  
All sizes are in mm

Verricelli ad asse verticale modelli NV-26, NV-28, NV-32, totalmente in acciaio inox AISI 316. Disponibili con differenti motorizzazioni sono suggeriti per imbarcazioni fino a 90m. Tutti i modelli per catene con traversino supportano le maglie kenter. Possibilità di avere la motorizzazione a 230V, 400V o idraulica.

Vertical windlasses models NV-26, NV-28, NV-32 are all in stainless steel AISI 316. Available with different drives and recommended for boats up to 90m. All the models for stud link chains support kenter link. Possibility of 230V, 400V or hydraulic drive.



CARATTERISTICHE	POTENZA MOTORE <i>ELECTRIC MOTOR</i>	11000W	15000W	22000W	HY
	TENSIONE DI ALIMENTAZIONE <i>MOTOR SUPPLY VOLTAGE</i>	230V/400V	230V/400V	230V/400V	N/A
	TIRO ISTANTANEO MASSIMO <i>MAXIMUM PULL</i>	9200 Kg	13800 Kg	18800 Kg	9425 Kg
	CARICO LAVORO AL SOLLEVAMENTO <i>LIFT WORKING LOAD</i>	4600 Kg	6950 Kg	9425 Kg	9425 Kg
	VELOCITÀ DI RECUPERO A CARICO <i>LINE SPEED</i>	13 mt/min	12 mt/min	12 mt/min	12 mt/min

CATEVA	Modello Verricello <i>Windlass Model</i>	NV-26	NV-28	NV-32	
	Barbotin / <i>Gipsy</i>	26 C.T.	28 C.T.	30 C.T.	32 C.T.
	Catena supportata <i>Chain supported</i>	26 Stud link	28 Stud link	30 Stud link	32 Stud link

11000	A	B	C	D	E	F	G
	550	440	320	535	MIN240	492	830

15000	A	B	C	D	E	F	G
	600	470	340	662	CUSTOM	470	1080

HY	A	B	C	D	E	F	G
	600	470	340	662	CUSTOM	540	730

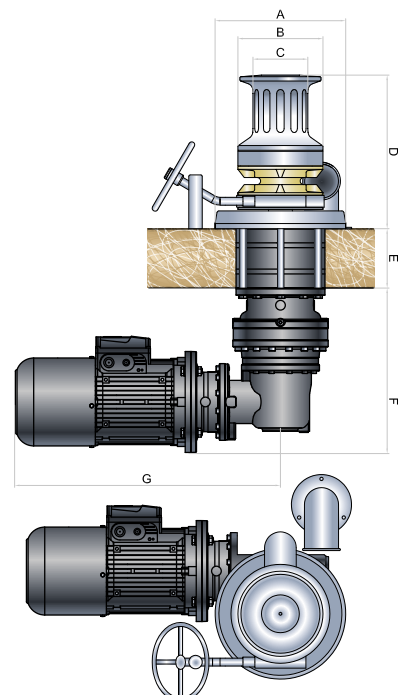

Tutte le misure indicate sono in mm  
All sizes are in mm





**VERRICELLI ORIZZONTALI**  
HORIZONTAL WINDLASSES

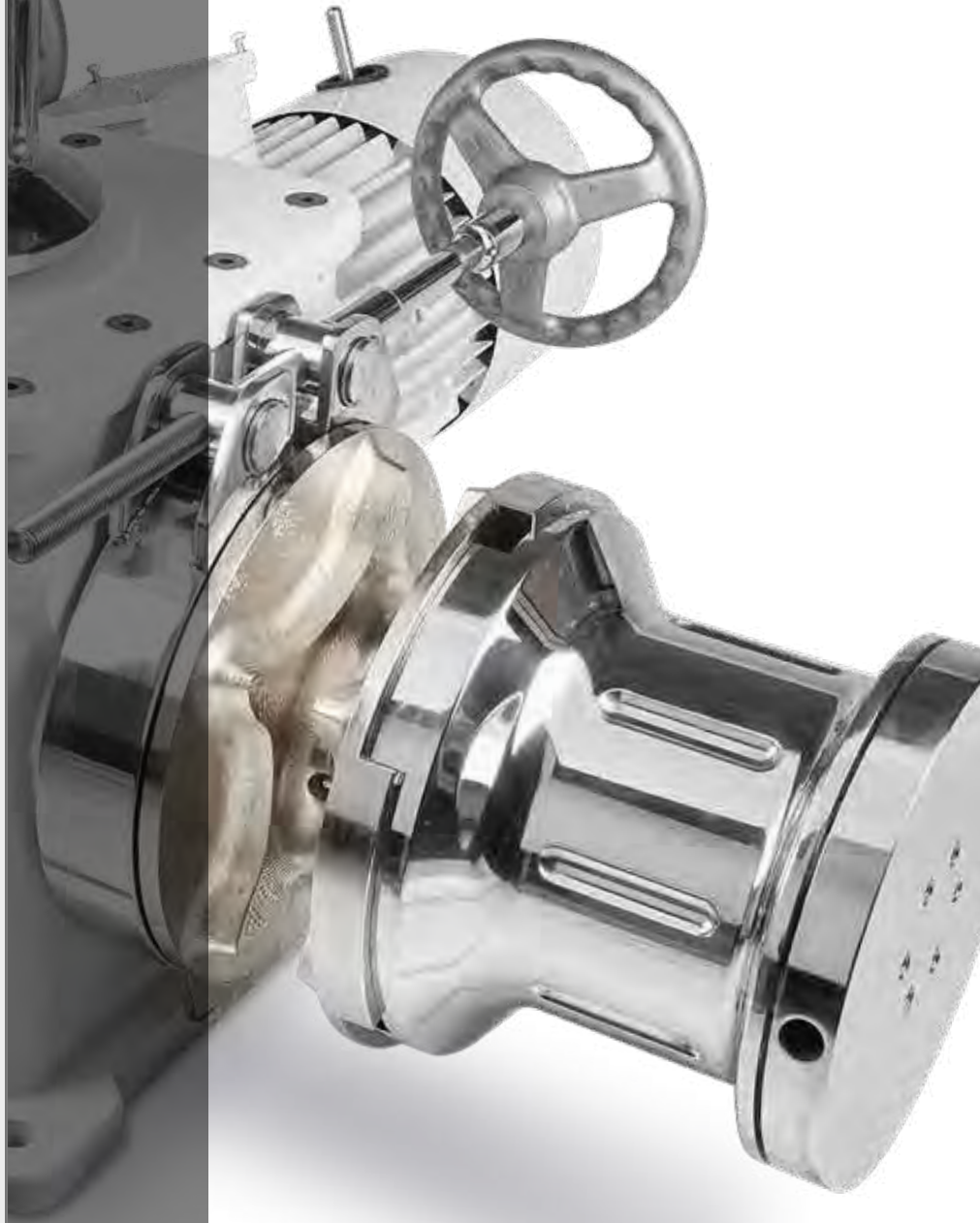



# CONFIGURAZIONE VERRICELLI

## windlass configurations

I verricelli ad asse orizzontale della serie RAJA, ACHERON, CESAR, NH-24 possono essere forniti con diverse configurazioni di campana e barbotin. La seguente tabella permette di definire quale sia il codice corretto della versione richiesta.

*The horizontal axis windlass series RAJA, ACHERON, CESAR, NH-24 can be supplied with different configurations of drum and gypsy. The following table allows to define the version and what's the correct code required.*

CODE	LEFT	RIGHT	TOP
A	DRUM	GIPSY	-
B	GIPSY	GIPSY	DRUM
C	DRUM	GIPSY	DRUM
D	-	GIPSY	DRUM
E	GIPSY	-	DRUM
F	GIPSY	DRUM	-
G	GIPSY	GIPSY	-
H	GIPSY	DRUM	DRUM
I	GIPSY	-	-
L	GIPSY + DRUM	GIPSY + DRUM	-
M	GIPSY + DRUM	GIPSY + DRUM	DRUM
N	GIPSY + DRUM	DRUM	-
O	GIPSY + DRUM	-	-
P	-	GIPSY + DRUM	-
Q	-	GIPSY	-

TESTA / TOP

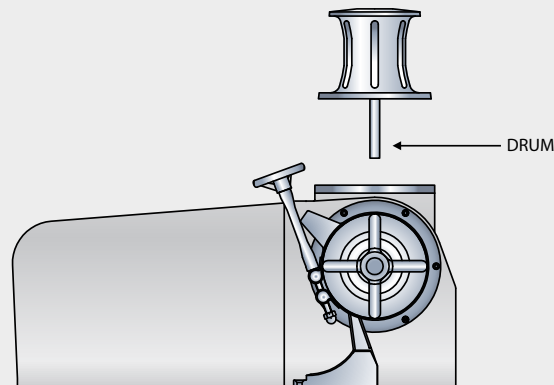

SINISTRA / LEFT

DESTRA / RIGHT

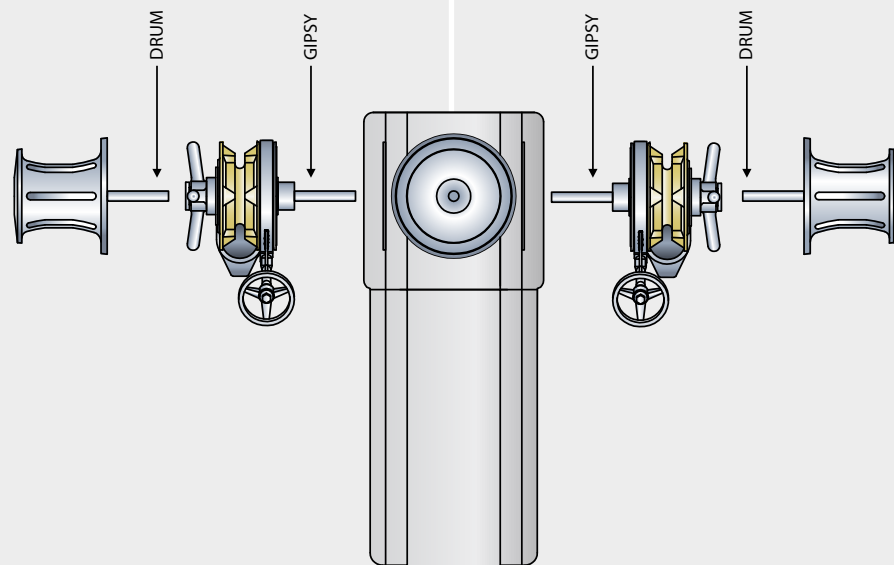



Verricello ad asse orizzontale in acciaio inox AISI 316. Disponibile con differenti motorizzazioni è suggerito per barche fino ai 12m. Il salpa ancore IKI può usare catena fino a 8mm ed è provvisto del sistema tendicima. Viene fornito con il sensore contametri già integrato.

*Stainless steel AISI 316 horizontal windlass. Available with different drives and recommended for boats up to 12m. IKI can use chains up to 8 mm and is equipped with rope tensioner. Comes with built-in chain counter sensor.*



**AUTOMATIC  
FREE FALL OPTION**

**OPTIONAL  
STAFFA DI MONTAGGIO  
MOUNTING BRACKET**



CIMA CATENA



RELÈ



CATENA



IP66  
MOTOR

CARATTERISTICHE	POTENZA MOTORE <i>ELECTRIC MOTOR</i>	500W	500W	800W	800W
	TENSIONE DI ALIMENTAZIONE <i>MOTOR SUPPLY VOLTAGE</i>	12V	24V	12V	24V
	TIRO ISTANTANEO MASSIMO <i>MAXIMUM PULL</i>	670 Kg	680 Kg	800 Kg	810 Kg
	CARICO LAVORO AL SOLLEVAMENTO <i>LIFT WORKING LOAD</i>	90 kg	90 Kg	100 Kg	100 Kg
	VELOCITÀ DI RECUPERO A CARICO <i>LINE SPEED</i>	25 mt/min	25 mt/min	28 mt/min	28 mt/min
	ASSORBIMENTO MEDIO <i>CURRENT ABSORPTION</i>	60 A	32 A	90 A	45 A
	PESO (SENZA CAMPANA) <i>WEIGHT (WITHOUT DRUM)</i>	11,5 Kg	11,5 Kg	11,5 Kg	11,5 Kg
	PESO (CON CAMPANA) <i>WEIGHT (WITH DRUM)</i>	12 Kg	12 Kg	12 Kg	12 Kg

CATENA	Barbotin / <i>Gipsy</i>	6mm			7mm				8mm			
	Catena supportata <i>Chain supported</i>	6mm ISO	6mm DIN766	3/16" BBB	7mm ISO	7mm DIN766	1/4" G4	1/4" BBB	8mm ISO	8mm DIN766	5/16" G4	5/16" BBB
	Cima supportata <i>Rope supported</i>	N/A			12mm 3-strand				12mm 3-strand			

500	A	B	C	D	E	F	G	H
	126	65	225	84.5	122	176	200	15/45

800	A	B	C	D	E	F	G	H
	126	65	225	84.5	122	176	200	15/45

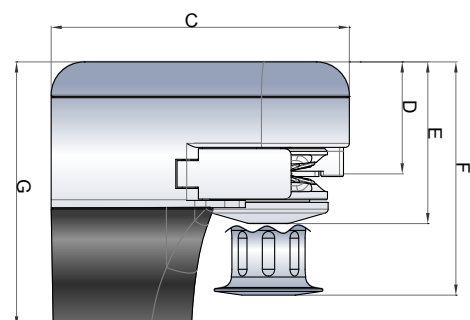
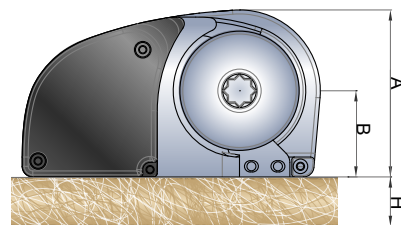

Tutte le misure indicate sono in mm  
All sizes are in mm

Verricello ad asse orizzontale in alluminio anticorodal anodizzato. L'OBI 500 può usare catena dal 6mm, 8mm di diametro ed è provvisto di sistema ten-dicima. Con differenti motorizzazioni è suggerito per barche fino ai 9m.

*Anticorodal anodized aluminium horizontal windlass. OBI 500 can use chains from 6mm, 8mm in diameter and is equipped with rope tensioner. With different drives and recommended for boats up to 9m.*



CARATTERISTICHE	POTENZA MOTORE <i>ELECTRIC MOTOR</i>	500W	500W	700W	700W
	TENSIONE DI ALIMENTAZIONE <i>MOTOR SUPPLY VOLTAGE</i>	12V	24V	12V	24V
	TIRO ISTANTANEO MASSIMO <i>MAXIMUM PULL</i>	630 Kg	640 Kg	670 Kg	680 Kg
	CARICO LAVORO AL SOLLEVAMENTO <i>LIFT WORKING LOAD</i>	90 Kg	90 Kg	100 Kg	100 Kg
	VELOCITÀ DI RECUPERO A CARICO <i>LINE SPEED</i>	23 mt/min	23 mt/min	25 mt/min	25 mt/min
	ASSORBIMENTO MEDIO <i>CURRENT ABSORPTION</i>	60 A	32 A	90 A	40 A
	PESO (SENZA CAMPANA) <i>WEIGHT (WITHOUT DRUM)</i>	N/A	N/A	N/A	N/A
	PESO (CON CAMPANA) <i>WEIGHT (WITH DRUM)</i>	8,2 Kg	8,2 Kg	8,8 Kg	8,8 Kg

CATENA	Barbotin / Gipsy	6mm			8mm			
	Catena supportata <i>Chain supported</i>	6mm ISO	6mm DIN766	3/16" BBB	8mm ISO	8mm DIN766	5/16" G4	5/16" BBB
	Cima supportata <i>Rope supported</i>	12mm 3-strand			N/A			

500	A	B	C	D	E	F	G
	158	138	144	282	82	80	15/45

700	A	B	C	D	E	F	G
	158	138	144	282	82	80	15/45

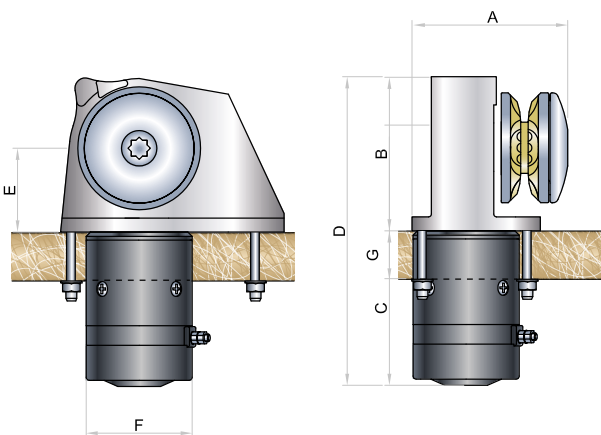

Tutte le misure indicate sono in mm  
All sizes are in mm



Verricello ad asse orizzontale in alluminio anticorodal anodizzato. L'OBI 1000 può usare catena dal 6mm, 8mm, 10mm di diametro. Con differenti motorizzazioni è suggerito per barche fino ai 15m.

*Anticorodal anodized aluminium horizontal windlass. OBI 1000 can use chains from 6mm, 8mm, 10mm in diameter. With different drives and recommended for boats up to 15m.*



CARATTERISTICHE	POTENZA MOTORE <i>ELECTRIC MOTOR</i>			
	1000W	1000W	1500W	1500W
TENSIONE DI ALIMENTAZIONE <i>MOTOR SUPPLY VOLTAGE</i>	12V	24V	12V	24V
TIRO ISTANTANEO MASSIMO <i>MAXIMUM PULL</i>	1250 Kg	1290 Kg	1350 Kg	1390 Kg
CARICO LAVORO AL SOLLEVAMENTO <i>LIFT WORKING LOAD</i>	130 Kg	140 Kg	150 Kg	160 Kg
VELOCITÀ DI RECUPERO A CARICO <i>LINE SPEED</i>	25 mt/min	25 mt/min	26 mt/min	26 mt/min
ASSORBIMENTO MEDIO <i>CURRENT ABSORPTION</i>	115 A	60 A	130 A	70 A
PESO (SENZA CAMPANA) <i>WEIGHT (WITHOUT DRUM)</i>	N/A	N/A	N/A	N/A
PESO (CON CAMPANA) <i>WEIGHT (WITH DRUM)</i>	17,3 Kg	17,3 Kg	17,6 Kg	17,6 Kg

CATENA	Barbotin / Gipsy		6mm				8mm				10mm		10 DIN 766	
	Catena supportata <i>Chain supported</i>	6mm ISO	6mm DIN766	3/16" BBB	8mm ISO	8mm DIN766	5/16" G4	5/16" BBB	10mm ISO4565	3/8" G4	10mm DIN766	3/8" BBB		
Cima supportata <i>Rope supported</i>		N/A		N/A				N/A		N/A		N/A		

1000	A	B	C	D	E	F	G
	230	265	166	331	90	114	15/65

1500	A	B	C	D	E	F	G
	230	265	166	331	90	114	15/65

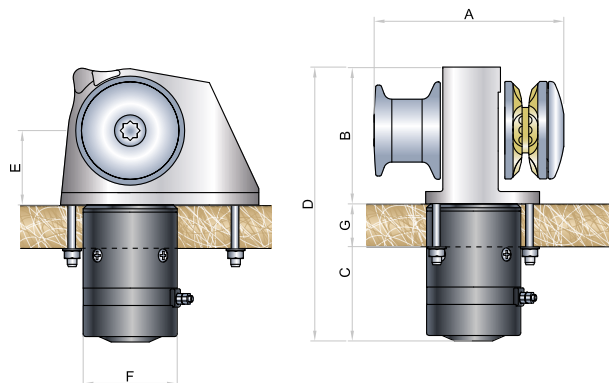

Tutte le misure indicate sono in mm  
All sizes are in mm



Verricello ad asse orizzontale in alluminio anticorodal anodizzato. Il DEVON può usare catena dal 6mm, 8mm, 10mm di diametro. Con differenti motorizzazioni è suggerito per barche fino ai 15m.

*Anticorodal anodized aluminium horizontal windlass. DEVON can use chains from 6mm, 8mm to 10 mm in diameter. With different drives and recommended for boats up to 15m.*



RELÈ

CATENA

CARATTERISTICHE	POTENZA MOTORE <i>ELECTRIC MOTOR</i>	1000W	1000W	1500W	1500W
	TENSIONE DI ALIMENTAZIONE <i>MOTOR SUPPLY VOLTAGE</i>	12V	24V	12V	24V
	TIRO ISTANTANEO MASSIMO <i>MAXIMUM PULL</i>	1290 Kg	1310 Kg	1350 Kg	1370 Kg
	CARICO LAVORO AL SOLLEVAMENTO <i>LIFT WORKING LOAD</i>	150 Kg	160 Kg	180 Kg	190 Kg
	VELOCITÀ DI RECUPERO A CARICO <i>LINE SPEED</i>	25 mt/min	25 mt/min	26 mt/min	26 mt/min
	ASSORBIMENTO MEDIO <i>CURRENT ABSORPTION</i>	115 A	60 A	130 A	70 A
	PESO (SENZA CAMPANA) <i>WEIGHT (WITHOUT DRUM)</i>	N/A	N/A	N/A	N/A
	PESO (CON CAMPANA) <i>WEIGHT (WITH DRUM)</i>	←————— 25 to 28 Kg —————→			

CATENA	Barbotin / Gipsy	6mm			8mm			10mm		10 DIN 766	
	Catena supportata <i>Chain supported</i>	6mm ISO	6mm DIN766	3/16" BBB	8mm ISO	8mm DIN766	5/16" G4	5/16" BBB	10mm ISO4565	3/8" G4	10mm DIN766

1000	A	B	C	D	E	F
	400	336	214	124	91	110

1500	A	B	C	D	E	F
	400	336	214	124	91	110

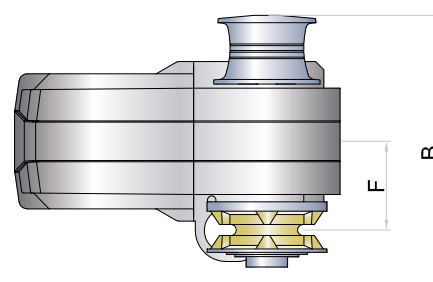
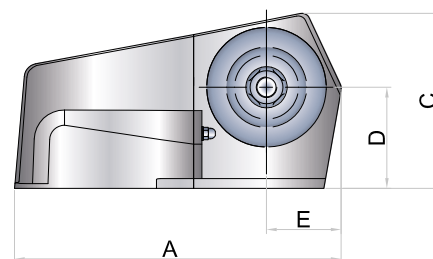

Tutte le misure indicate sono in mm  
All sizes are in mm

Verricello salpa ancora ad asse orizzontale FYN. Corpo riduttore in alluminio anticorrosione anodizzato con campana in acciaio inox, indipendente dal barbotin. Barbotin per catena diametro 8mm, 10mm ISO, 10mm DIN766, 12mm ISO, 13mm DIN766. Adatto per barche fino a 18mt.

*FYN horizontal windlass with anodized aluminium gearbox and stainless steel drum. Gypsy for 8mm, 10mm ISO, 10mm DIN766, 12mm ISO, 13mm DIN766 chains. Suitable for boats up to 18mt.*



RELÈ

CARATTERISTICHE	POTENZA MOTORE <i>ELECTRIC MOTOR</i>	1700W	1700W
	TENSIONE DI ALIMENTAZIONE <i>MOTOR SUPPLY VOLTAGE</i>	12V	24V
	TIRO ISTANTANEO MASSIMO <i>MAXIMUM PULL</i>	1700 Kg	1750 Kg
	CARICO LAVORO AL SOLLEVAMENTO <i>LIFT WORKING LOAD</i>	260 Kg	270 Kg
	VELOCITÀ DI RECUPERO A CARICO <i>LINE SPEED</i>	14 mt/min	14 mt/min
	ASSORBIMENTO MEDIO <i>CURRENT ABSORPTION</i>	135 A	75 A
	PESO (CON CAMPANA) <i>WEIGHT (WITH DRUM)</i>	35 Kg	35 Kg

CATENA	Barbotin / <i>Gypsy</i>	8mm				10mm		10 DIN 766		12mm	1/2" HT
	Catena supportata <i>Chain supported</i>	8mm ISO	8mm DIN766	5/16" G4	5/16" BBB	10mm ISO4565	3/8" G4	10mm DIN766	3/8" BBB	12mm ISO	1/2" HT

1700	A	B	C	D	E	F
	445	363	278	162	128	100

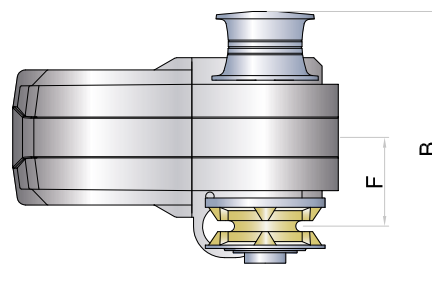
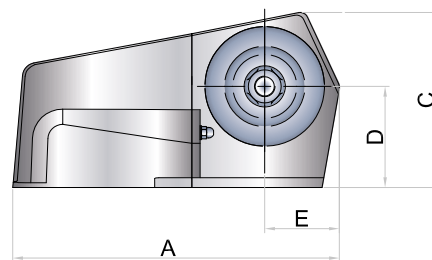

Tutte le misure indicate sono in mm  
All sizes are in mm



Verricello ad asse orizzontale in alluminio anticorodal anodizzato con campana in acciaio INOX. Il RAJA può usare catena dal 10mm al 14mm di diametro. Con differenti motorizzazioni è suggerito per barche fino ai 26m. Disponibile in differenti configurazioni di campane e barbotin. Per la versione desiderata consultare la tabella configurazione verricelli.

*Anticorodal aluminium horizontal axis windlass. Whit stainless steel drum The RAJA can use chains from 10 mm to 14 mm in diameter. With different drives and recommended for boats up to 26m. Available in different drum and gypsy configurations. For the version see the windlass configuration table.*

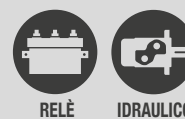

Possibilità Verniciatura Bianca  
White Painting Option

CARATTERISTICHE	POTENZA MOTORE <i>ELECTRIC MOTOR</i>	2300W	2700W	3600W	HY
	TENSIONE DI ALIMENTAZIONE <i>MOTOR SUPPLY VOLTAGE</i>	24V	24V	230V/400V	N/A
	TIRO ISTANTANEO MASSIMO <i>MAXIMUM PULL</i>	2800 Kg	3000KG	3200 Kg	700 Kg
	CARICO LAVORO AL SOLLEVAMENTO <i>LIFT WORKING LOAD</i>	520 Kg	590 Kg	700 Kg	700 Kg
	VELOCITÀ DI RECUPERO A CARICO <i>LINE SPEED</i>	12 mt/min	12 mt/min	12 mt/min	12 mt/min
	ASSORBIMENTO MEDIO <i>CURRENT ABSORPTION</i>	120 A	150 A	N/A	N/A
PESO (CON CAMPANA) <i>WEIGHT (WITH DRUM)</i>	←————— 55 to 70 Kg —————→				

CATENA	Barbotin / Gipsy	10mm		10 DIN 766		12mm			14mm	1/2" HT	14 C.T.	12,5 C.T.
	Chain supported	10mm ISO4565	3/8" G4	10mm DIN766	3/8" BBB	12mm ISO	13mm DIN 766	7/16" G4	14mm ISO	1/2" HT	14 Stud link	12,5 Stud link

2300	A	B	C	D	E	F	G	H
	632	500	400	280	210	165	260	240

2700	A	B	C	D	E	F	G	H
	632	500	400	280	210	165	260	240

3600AC	A	B	C	D	E	F	G	H
	632	500	400	280	210	165	260	240

HY	A	B	C	D	E	F	G	H
	632	500	400	280	210	165	260	240

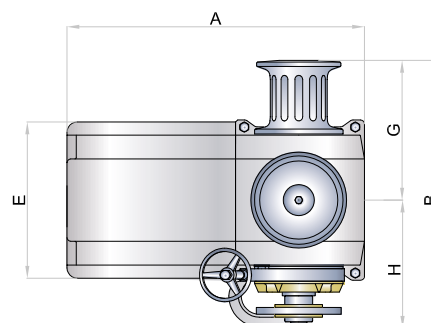
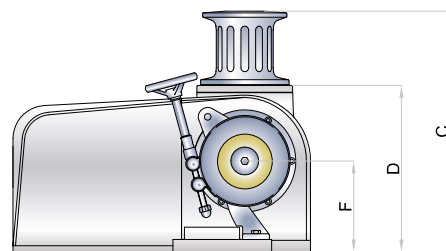

Tutte le misure indicate sono in mm  
All sizes are in mm



Verricello ad asse orizzontale in alluminio anticorrosivo verniciato bianco con campana in acciaio inox. L'ACHERON può usare catena dal 12mm al 19mm C.T. di diametro. Con differenti motorizzazioni è suggerito per barche fino ai 55m. Disponibile in differenti configurazioni di campane e barbotin. Per la versione desiderata consultare la tabella configurazione verricelli.

White painted anticorrosive aluminium horizontal axis windlass with stainless steel drum. The ACHERON can use chains from 12mm to 19mm with stud link in diameter. With different drives and recommended for boats up to 55 meters. Available in different drum and gypsy configurations. For the version see the windlass configuration table.

CARATTERISTICHE	POTENZA MOTORE <i>ELECTRIC MOTOR</i>	3500W	4000W	5500W	7500W	HY
	TENSIONE DI ALIMENTAZIONE <i>MOTOR SUPPLY VOLTAGE</i>	24V	230V/400V	230V/400V	230V/400V	N/A
	TIRO Istantaneo Massimo <i>MAXIMUM PULL</i>	4800 Kg	5000 Kg	5500 Kg	5800 Kg	2600 Kg
	CARICO LAVORO AL SOLLEVAMENTO <i>LIFT WORKING LOAD</i>	1500 Kg	1600 Kg	2000 Kg	2600 Kg	2600 Kg
	VELOCITÀ DI RECUPERO A CARICO <i>LINE SPEED</i>	12 mt/min	12 mt/min	12 mt/min	12 mt/min	12 mt/min
	ASSORBIMENTO MEDIO <i>CURRENT ABSORPTION</i>	195 A	N/A	N/A	N/A	N/A
PESO (CON CAMPANA) <i>WEIGHT (WITH DRUM)</i>	←————— 200 to 265 Kg —————→					

CATENA	Barbotin / Gipsy	12mm			13 DIN 764	14mm	16mm	16 DIN 766	18mm	20mm	12,5 C.T.	14 C.T.	16 C.T.	17,5 C.T.
	Catena supportata <i>Chain supported</i>	12mm ISO	13mm DIN 766	7/16" G4	13mm DIN 764	14mm ISO	16mm ISO	16mm DIN 766	18mm ISO	20mm ISO	12,5 Stud link	14 Stud link	16 Stud link	17,5 Stud link

3500	A	B	C	D	E	F	G	H
	725	678	583	400	380	220	338	340

4000AC	A	B	C	D	E	F	G	H
	725	678	583	400	380	220	338	340

5500AC	A	B	C	D	E	F	G	H
	725	678	583	400	380	220	338	340

7500AC	A	B	C	D	E	F	G	H
	907*	678	583	400	380	220	338	340

(\* senza copertura motore / without motor cover)

HY	A	B	C	D	E	F	G	H
	725	678	583	400	380	220	338	340

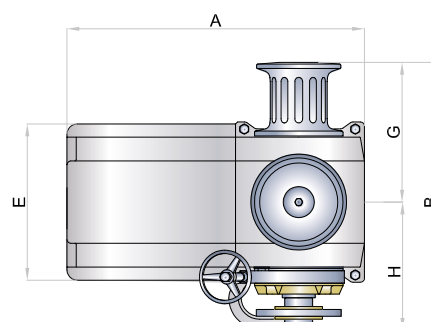
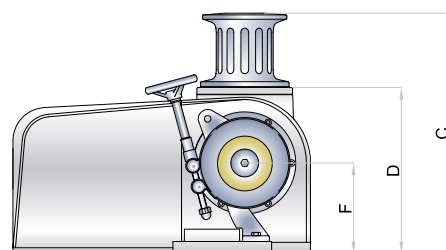

Tutte le misure indicate sono in mm  
All sizes are in mm



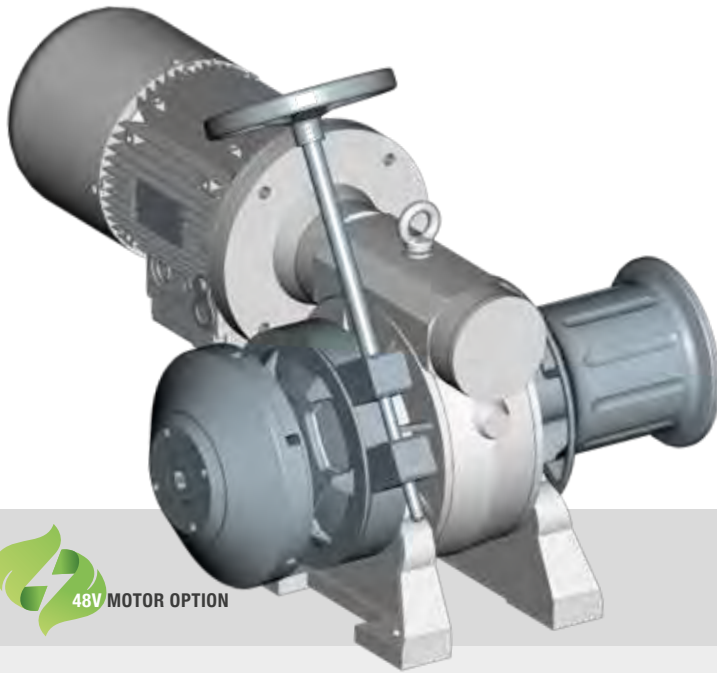

Il verricello salpa ancora CW-16 incorpora un riduttore a vite senza fine lubrificato ad olio accoppiato direttamente a un motore idraulico, DC 24V, DC 48V o elettrico trifase. L'argano standard CW-16 può portare un singolo barbotin per catene fino 16mm con traversino. È possibile avere il salpa ancora con l'opzione del doppio barbotin. Il riduttore è dotato di verniciatura per l'ambiente marino.

The CW-16 windlass incorporates an oil-lubricated worm gearbox coupled directly to a hydraulic, DC 24V, DC 48V or three-phase electric motor. The standard CW-16 winch can carry a single gypsy for chains up to 16mm stud link. It is possible to have the anchor windlass with the double gypsy option. The gearbox come with a marine environment paint.



CARATTERISTICHE	POTENZA MOTORE <i>ELECTRIC MOTOR</i>	3500W	3000W	4000W	HY
	TENSIONE DI ALIMENTAZIONE <i>MOTOR SUPPLY VOLTAGE</i>	24V	230V/400V	230V/400V	-
	TIRO ISTANTANEO MASSIMO <i>MAXIMUM PULL</i>	3000 Kg	4800 Kg	5900 Kg	2500 Kg
	CARICO LAVORO AL SOLLEVAMENTO <i>LIFT WORKING LOAD</i>	1100 Kg	1200 Kg	1600 Kg	2500 Kg
	VELOCITÀ DI RECUPERO A CARICO <i>LINE SPEED</i>	14 mt/min	12 mt/min	12 mt/min	12 mt/min
	ASSORBIMENTO MEDIO <i>CURRENT ABSORPTION</i>	N/A	N/A	N/A	N/A
	PESO (CON CAMPANA) <i>WEIGHT (WITH DRUM)</i>				

CATENA	Barbotin / Gipsy			12mm		1/2" HT	13DIN764	14mm	16mm	16DIN766	12,5 C.T.	14 C.T.	16 C.T.
	Catena supportata <i>Chain supported</i>	12mm ISO	13mm DIN 766	7/16" G4	1/2" HT	13mm DIN764	14mm ISO	16mm ISO	16mm DIN766	12,5 Stud link	14 Stud link	16 Stud link	

3500	A	B	C	D
	700	500	300	450

3000	A	B	C	D
	780	500	300	450

4000	A	B	C	D
	800	500	300	450

HY	A	B	C	D
	480	500	300	450

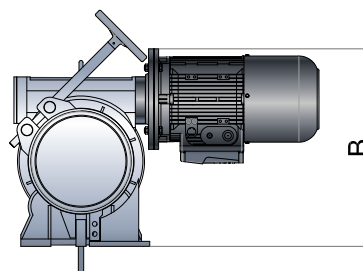
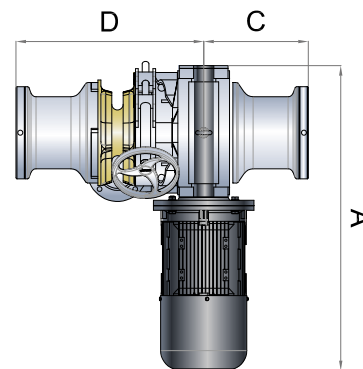

Tutte le misure indicate sono in mm  
All sizes are in mm

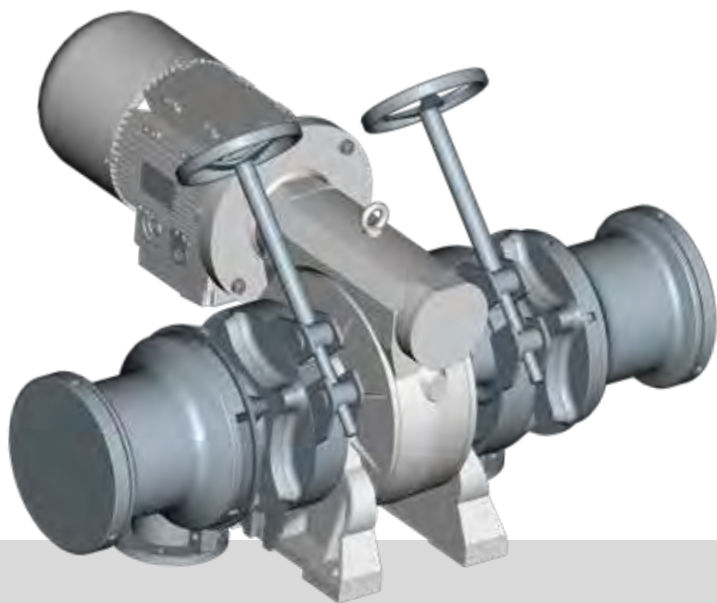

Il verricello salpa ancora CW-19 incorpora un riduttore a vite senza fine lubrificato ad olio accoppiato direttamente a un motore idraulico o elettrico trifase. L'argano standard CW-19 può portare un singolo barbotin per catene fino 19mm con traversino. È possibile avere il salpa ancora con l'opzione del doppio barbotin. Il riduttore è dotato di verniciatura per l'ambiente marino.

*The CW-19 windlass incorporates an oil-lubricated worm gearbox coupled directly to a hydraulic or three-phase electric motor. The standard CW-19 winch can carry a single gypsy for chains up to 19mm stud link. It is possible to have the anchor windlass with the double gypsy option. The gearbox come with a marine environment paint.*

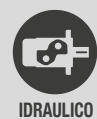

IDRAULICO

CARATTERISTICHE	POTENZA MOTORE <i>ELECTRIC MOTOR</i>	5500W	7500W	HY
	TENSIONE DI ALIMENTAZIONE <i>MOTOR SUPPLY VOLTAGE</i>	230V/400V	230V/400V	N/A
	TIRO ISTANTANEO MASSIMO <i>MAXIMUM PULL</i>	4800 Kg	5900 Kg	3000 Kg
	CARICO LAVORO AL SOLLEVAMENTO <i>LIFT WORKING LOAD</i>	1500 Kg	1600 Kg	3000 Kg
	VELOCITÀ DI RECUPERO A CARICO <i>LINE SPEED</i>	13 mt/min	13 mt/min	12 mt/min
	ASSORBIMENTO MEDIO <i>CURRENT ABSORPTION</i>	N/A	N/A	N/A
	PESO (CON CAMPANA) <i>WEIGHT (WITH DRUM)</i>			

CATENA	Barbotin / Gipsy	16 C.T.	17,5 C.T.	19 C.T.
	Catena supportata <i>Chain supported</i>	16 Stud link	17,5 Stud link	19 Stud link

3500	A	B	C	D
	910	600	310	560

7500	A	B	C	D
	910	600	310	560

HY	A	B	C	D
	590	600	310	560

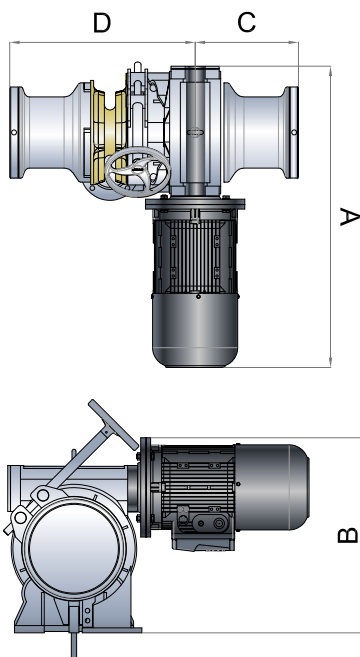

Tutte le misure indicate sono in mm  
All sizes are in mm

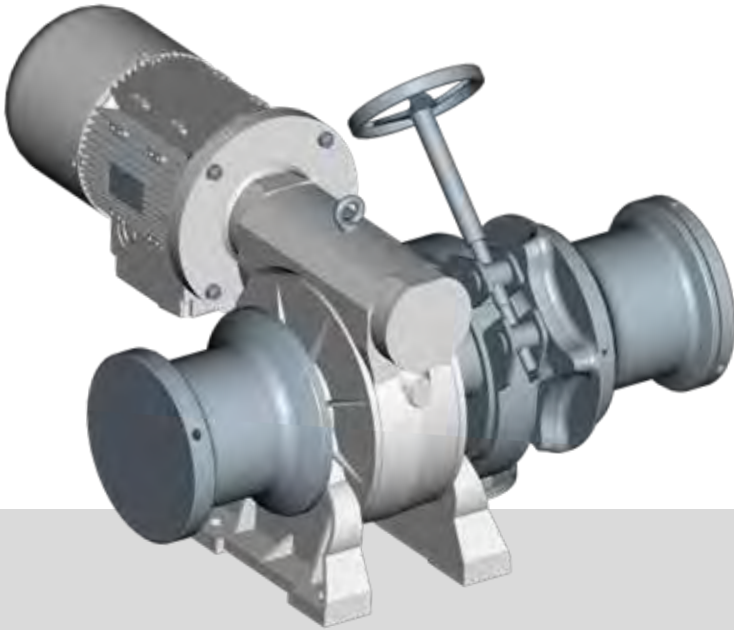

Il verricello salpa ancora CW-20 incorpora un riduttore a vite senza fine lubrificato ad olio accoppiato direttamente a un motore idraulico o elettrico trifase. L'argano standard CW-20 può portare un singolo barbotin per catene fino 20,5mm con traversino. È possibile avere il salpa ancora con l'opzione del doppio barbotin. Il riduttore è dotato di verniciatura per l'ambiente marino.

*The CW-20 windlass incorporates an oil-lubricated worm gearbox coupled directly to a hydraulic or three-phase electric motor. The standard CW-20 winch can carry a single gypsy for chains up to 20,5mm stud link. It is possible to have the anchor windlass with the double gypsy option. The gearbox come with a marine environment paint.*



IDRAULICO

CARATTERISTICHE	POTENZA MOTORE <i>ELECTRIC MOTOR</i>	7500W	HY
	TENSIONE DI ALIMENTAZIONE <i>MOTOR SUPPLY VOLTAGE</i>	230V/400V	N/A
	TIRO ISTANTANEO MASSIMO <i>MAXIMUM PULL</i>	6100 Kg	3000 Kg
	CARICO LAVORO AL SOLLEVAMENTO <i>LIFT WORKING LOAD</i>	2400 Kg	3000 Kg
	VELOCITÀ DI RECUPERO A CARICO <i>LINE SPEED</i>	14 mt/min	12 mt/min
	ASSORBIMENTO MEDIO <i>CURRENT ABSORPTION</i>	N/A	N/A
	PESO (CON CAMPANA) <i>WEIGHT (WITH DRUM)</i>		

CATENA	Barbotin / Gypsy	20,5 C.T.
	Catena supportata <i>Chain supported</i>	20,5 Stud link

7500	A	B	C	D
	910	600	310	560

HY	A	B	C	D
	590	600	310	560

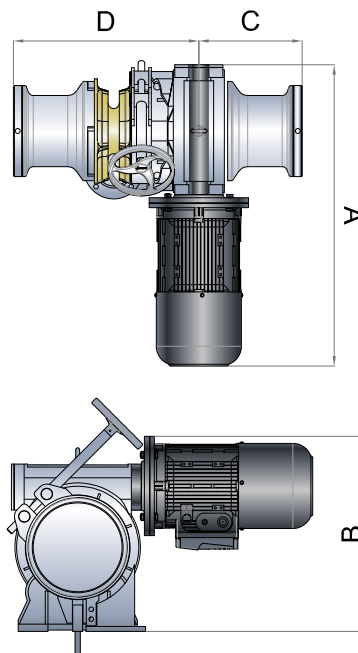

Tutte le misure indicate sono in mm  
All sizes are in mm

Verricello ad asse orizzontale in acciaio inox. L'NH-24 può usare catena fino a 24mm C.T. di diametro. Con differenti motorizzazioni è suggerito per barche fino ai 80m. Disponibile in differenti configurazioni di campane e barbotin. Per la versione desiderata consultare la tabella configurazione verricelli.

*Stainless steel horizontal axis windlass. The NH-24 can use chains up to from 24mm with stud link. With different drives and recommended for boats up to 80 meters Available in different drum and gypsy configurations. For the version see the windlass configuration table.*

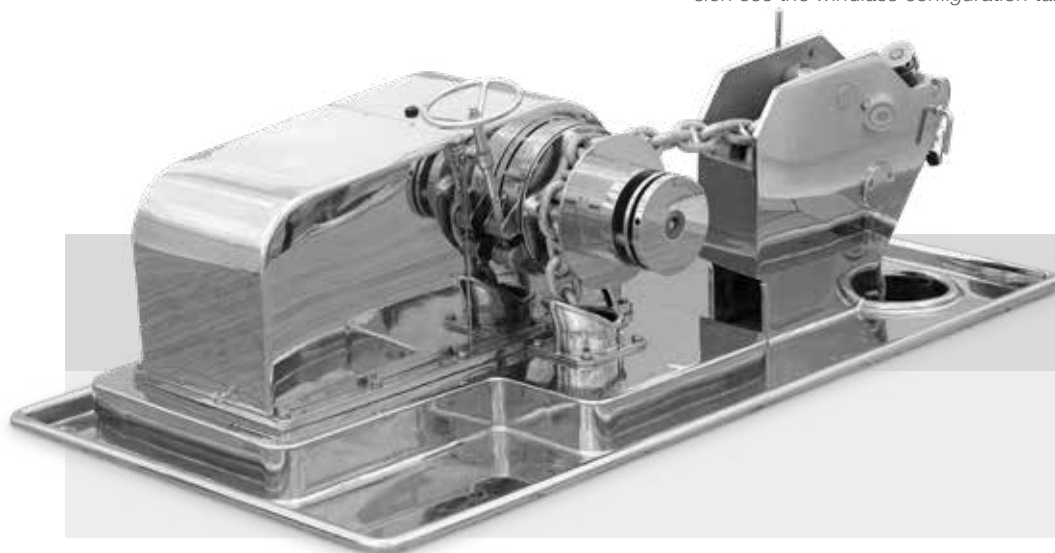

IDRAULICO

CARATTERISTICHE	POTENZA MOTORE <i>ELECTRIC MOTOR</i>	9200W	11000W	HY
	TENSIONE DI ALIMENTAZIONE <i>MOTOR SUPPLY VOLTAGE</i>	230V/400V	230V/400V	N/A
	CARICO LAVORO MASSIMO ISTANTANEO <i>MAXIMUM LIFT LOAD</i>	7200 Kg	8900 Kg	4400 Kg
	CARICO LAVORO AL SOLLEVAMENTO <i>LIFT WORKING LOAD</i>	3600 Kg	4400 Kg	4400 Kg
	VELOCITÀ DI RECUPERO A CARICO <i>LINE SPEED</i>	12 mt/min	12 mt/min	12 mt/min

CATENA	Barbotin / Gipsy	19 C.T.	20,5 C.T.	22 C.T.	24 C.T.
	Catena supportata <i>Chain supported</i>	19 Stud link	20,5 Stud link	22 Stud link	24 Stud link

9200AC	A	B	C	D	E	F	G	H
	1208	1161	918	602	600	355	508	653

1100AC	A	B	C	D	E	F	G	H
	1208	1161	918	602	600	355	508	653

HY	A	B	C	D	E	F	G	H
	1208	1161	918	602	600	355	508	653

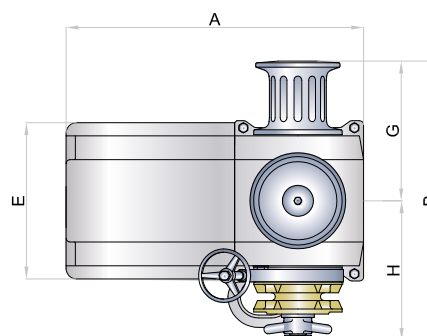
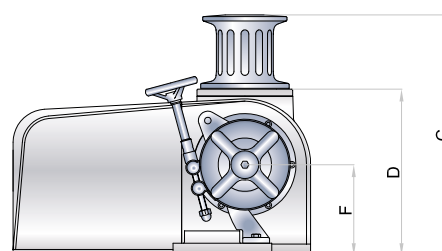

Tutte le misure indicate sono in mm  
All sizes are in mm



**OPTIONAL**



**CASSETTA CONTROLLO  
INVERTER**  
CONTROL PANEL/INVERTER



Verricello ad asse orizzontale verniciato bianco con campana in acciaio inox. Il CAESAR può usare catena dal 16mm C.T. a 20,5mm C.T. di diametro. Con differenti motorizzazioni è suggerito per barche fino ai 65m. Disponibile in differenti configurazioni di campane e barbotin. Per la versione desiderata consultare la tabella configurazione verricelli.

White painted horizontal axis windlass. With stainless steel drum. The CAESAR can use chains from 16mm with stud link to 20,5mm with stud link in diameter. With different drives and recommended for boats up to 65 meters Available in different drum and gypsy configurations. For the version see the windlass configuration table.



IDRAULICO

CARATTERISTICHE	POTENZA MOTORE <i>ELECTRIC MOTOR</i>	7500W	9200W	HY
	TENSIONE DI ALIMENTAZIONE <i>MOTOR SUPPLY VOLTAGE</i>	230V/400V	230V/400V	N/A
	TIRO ISTANTANEO MASSIMO <i>MAXIMUM PULL</i>	3600 Kg	4300 Kg	3400 Kg
	CARICO LAVORO AL SOLLEVAMENTO <i>LIFT WORKING LOAD</i>	2700 Kg	3200 Kg	3400 Kg
	VELOCITÀ DI RECUPERO A CARICO <i>LINE SPEED</i>	10 mt/min	10 mt/min	10 mt/min
	ASSORBIMENTO MEDIO <i>CURRENT ABSORPTION</i>	N/A	N/A	N/A
	PESO (CON CAMPANA) <i>WEIGHT (WITH DRUM)</i>	← 340 to 380 Kg →		

CATENA	Barbotin / Gipsy	16 C.T.	17,5 C.T.	19 C.T.	20,5 C.T.
	Catena supportata <i>Chain supported</i>	16 Stud link	17,5 Stud link	19 Stud link	20,5 Stud link

7500AC	A	B	C	D	E	F	G	H
	915*	900	675	465	430	260	475	425

(\*) senza copertura motore / without motor cover

9200AC	A	B	C	D	E	F	G	H
	915*	900	675	465	430	260	475	425

(\*) senza copertura motore / without motor cover

HY	A	B	C	D	E	F	G	H
	915	900	675	465	430	260	475	425

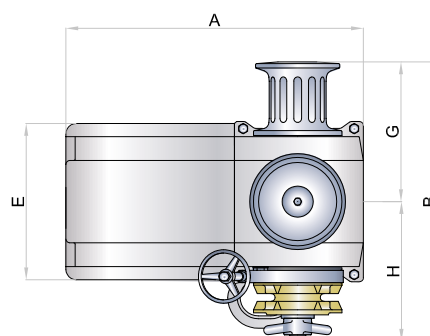
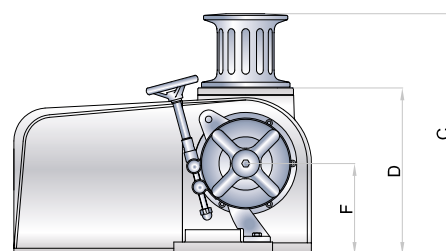

Tutte le misure indicate sono in mm  
All sizes are in mm

**VERRICELLI DA TONNEGGIO**  
CAPSTANS



Verricello da tonneggio per il recupero del tender con campana in acciaio inox già predisposta per attacco cinghia a fettuccia (non fornita di serie con il prodotto)

Capstan winch for recovering the tender boat with stainless steel drum already set for belt and snap-hook fastening. (not supplied as standard with the product)



RELÈ

CARATTERISTICHE	RT02		RT03		
	800W	800W	1500W	1500W	1500W
POTENZA MOTORE <i>ELECTRIC MOTOR</i>	800W	800W	1500W	1500W	1500W
TENSIONE DI ALIMENTAZIONE <i>MOTOR SUPPLY VOLTAGE</i>	12V	24V	12V	24V	230-400V
TIRO ISTANTANEO MASSIMO <i>MAXIMUM PULL</i>	600 Kg	650 Kg	1000 Kg	1100 Kg	1800 Kg
CARICO LAVORO AL SOLLEVAMENTO <i>LIFT WORKING LOAD</i>	200 Kg	220 Kg	400 Kg	450 Kg	900 Kg
VELOCITÀ DI RECUPERO A CARICO <i>LINE SPEED</i>	4 mt/min	4 mt/min	4 mt/min	4 mt/min	6 mt/min
ASSORBIMENTO MEDIO <i>CURRENT ABSORPTION</i>	90 A	45 A	130 A	70 A	N/A
PESO <i>WEIGHT</i>	<----- 25 to 60 Kg ----->				

### RT02

800	A	B	C	D
	419	60	223	198

### RT03

1500	A	B	C	D
	494	60	262	198

1500AC	A	B	C	D
	525	60	282	198

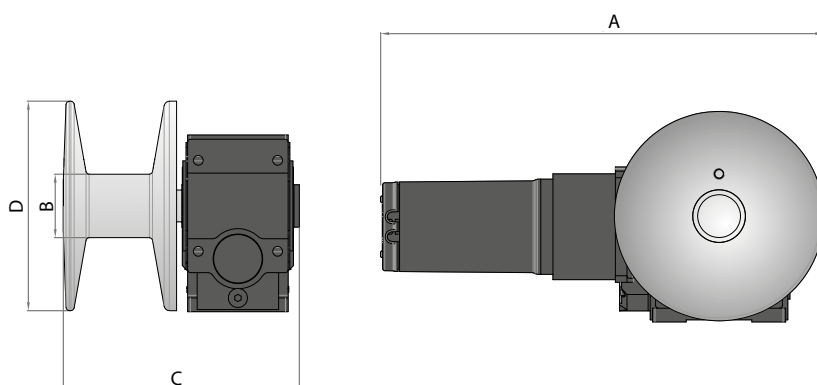

Tutte le misure indicate sono in mm  
All sizes are in mm



Verricello da tonneggio per il recupero del tender con campana in acciaio inox già predisposta per attacco cinghia a fettuccia (non fornita di serie con il prodotto)



Capstan winch for recovering the tender boat with stainless steel drum already set for belt and snap-hook fastening. (not supplied as standard with the product)



RELÈ

CARATTERISTICHE	POTENZA MOTORE <i>ELECTRIC MOTOR</i>	HYD	2200W
	TENSIONE DI ALIMENTAZIONE <i>MOTOR SUPPLY VOLTAGE</i>	N/A	230-400V
	TIRO ISTANTANEO MASSIMO <i>MAXIMUM PULL</i>	1500 Kg	1500 Kg
	CARICO LAVORO AL SOLLEVAMENTO <i>LIFT WORKING LOAD</i>	2800 Kg	2800 Kg
	VELOCITÀ DI RECUPERO A CARICO <i>LINE SPEED</i>	4 mt/min	4 mt/min
	ASSORBIMENTO MEDIO <i>CURRENT ABSORPTION</i>	N/A	N/A
	PESO <i>WEIGHT</i>	<----- 30 to 65 Kg ---->	

HYD	A	B	C	D
	491	250	60	435

2200	A	B	C	D
	696	250	60	640

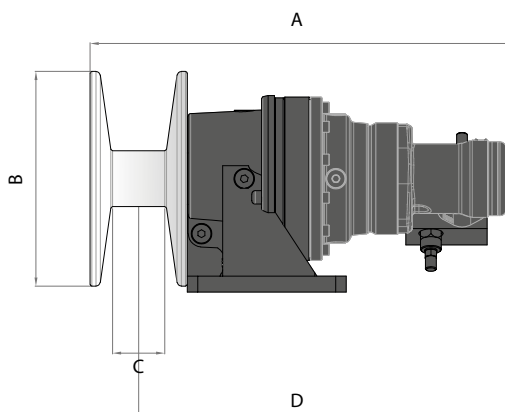

Verricello da tonneggio per il recupero del tender con campana in alluminio anodizzato già predisposta per attacco cinghia e moschetone. (non forniti di serie con il prodotto)

Capstan winch for recovering the tender boat with anodized aluminum drum already set for belt and snap-hook fastening. (Not supplied as standard with the product)



CARATTERISTICHE	POTENZA MOTORE <i>ELECTRIC MOTOR</i>	500W	500W	1000W	1000W	1500W	1500W
	TENSIONE DI ALIMENTAZIONE <i>MOTOR SUPPLY VOLTAGE</i>	12V	24V	12V	24V	12V	24V
	TIRO ISTANTANEO MASSIMO <i>MAXIMUM PULL</i>	650 Kg	660 Kg	1450 Kg	1500 Kg	1650 Kg	1700 Kg
	CARICO LAVORO AL SOLLEVAMENTO <i>LIFT WORKING LOAD</i>	90 Kg	90 Kg	230 Kg	250 Kg	250 Kg	280 Kg
	VELOCITÀ DI RECUPERO A CARICO <i>LINE SPEED</i>	12 mt/min	12 mt/min	11 mt/min	11 mt/min	11 mt/min	11 mt/min
	ASSORBIMENTO MEDIO <i>CURRENT ABSORPTION</i>	60 A	32 A	115 A	60 A	130 A	70 A
	PESO <i>WEIGHT</i>	8,5 Kg	8,6 Kg	15,5 Kg	16 Kg	15,5 Kg	16 Kg

500	A	B	C	D	E
	360	165	195	150	40

1000	A	B	C	D	E
	380	225	297	208	60

1500	A	B	C	D	E
	380	225	297	208	60

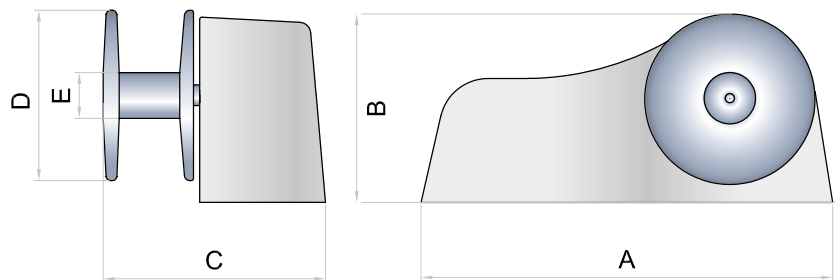

Tutte le misure indicate sono in mm  
All sizes are in mm

Verricello da tonneggio per il recupero del tender con campana in acciaio inox AISI 316 già predisposta per attacco cinghia e moschetone. (non forniti di serie con il prodotto)

Capstan winch for recovering the tender boat with stainless steel AISI 316 drum already set for belt and snap-hook fastening. (Not supplied as standard with the product)



IDRAULICO



RELÈ



IP67

MOTOR

CARATTERISTICHE	POTENZA MOTORE <i>ELECTRIC MOTOR</i>								
	1000W	1000W	1500W	1500W	1700W	1700W	HY	2000W	
TENSIONE DI ALIMENTAZIONE <i>MOTOR SUPPLY VOLTAGE</i>	12V	24V	12V	24V	12V	24V	N/A	230V/400V	
TIRO ISTANTANEO MASSIMO <i>MAXIMUM PULL</i>	1020 Kg	1060 Kg	1250 Kg	1290 Kg	1650 Kg	1700 Kg	380 Kg	1700 Kg	
CARICO LAVORO AL SOLLEVAMENTO <i>LIFT WORKING LOAD</i>	130 Kg	140 Kg	150 Kg	160 Kg	220 Kg	240 Kg	380 Kg	250 Kg	
VELOCITÀ DI RECUPERO A CARICO <i>LINE SPEED</i>	25 mt/min	25 mt/min	26 mt/min	26 mt/min	26 mt/min	26 mt/min	26 mt/min	12 mt/min	
ASSORBIMENTO MEDIO <i>CURRENT ABSORPTION</i>	115A	60A	130A	70A	185A	90A	N/A	N/A	
PESO <i>WEIGHT</i>	19Kg	19Kg	19,6Kg	19,6Kg	24Kg	24Kg	21 Kg	25 Kg	

1000	A	B	C	D	E	F	G	H
	208	60	113	25/50	114	150	250	80

1500	A	B	C	D	E	F	G	H
	208	60	113	25/50	114	150	250	80

1700	A	B	C	D	E	F	G	H
	208	60	113	25/50	127	175	330	80

HY	A	B	C	D	E	F	G	H
	208	60	113	25/50	102	175	170	80

2000	A	B	C	D	E	F	G	H
	208	60	113	25/50	165	210	350	80

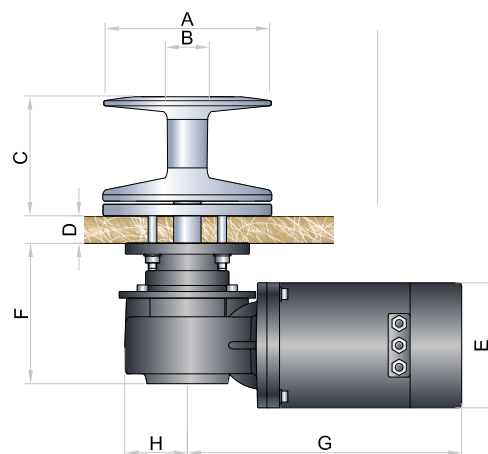

Tutte le misure indicate sono in mm  
All sizes are in mm

Verricello da tonneggio in acciaio inox AISI 316. Con differenti motorizzazioni è suggerito per barche fino ai 13m.

*Stainless steel AISI 316 capstan winch, with different drives and recommended for boats up to 13 meters.*



CARATTERISTICHE	POTENZA MOTORE <i>ELECTRIC MOTOR</i>	500W	500W	700W	700W
	TENSIONE DI ALIMENTAZIONE <i>MOTOR SUPPLY VOLTAGE</i>	12V	24V	12V	24V
	TIRO ISTANTANEO MASSIMO <i>MAXIMUM PULL</i>	650 Kg	670 Kg	750 Kg	760 Kg
	CARICO LAVORO AL SOLLEVAMENTO <i>LIFT WORKING LOAD</i>	90 Kg	90 Kg	100 Kg	100 Kg
	VELOCITÀ DI RECUPERO A CARICO <i>LINE SPEED</i>	23 mt/min	23 mt/min	25 mt/min	25 mt/min
	ASSORBIMENTO MEDIO <i>CURRENT ABSORPTION</i>	60 A	32 A	90 A	40 A
	PESO <i>WEIGHT</i>	8,6 Kg	8,6 Kg	9,7 Kg	9,7 Kg

500	A	B	C	D	E	F	G	H
	109	56	100	25/50	82	110	231	45

700	A	B	C	D	E	F	G	H
	109	56	100	25/50	82	110	220	45

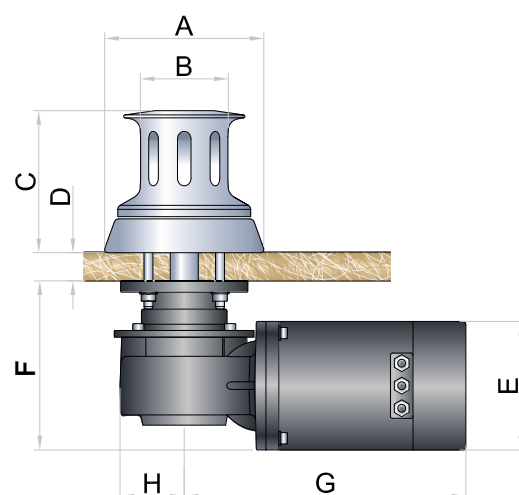

Tutte le misure indicate sono in mm  
All sizes are in mm



Verricello da tonneggio in acciaio inox AISI 316. Con differenti motorizzazioni è suggerito per barche fino ai 17m.

*Stainless steel AISI 316 capstan winch, with different drives and recommended for boats up to 17 meters.*



RELÉ



IP67

MOTOR

CARATTERISTICHE	POTENZA MOTORE <i>ELECTRIC MOTOR</i>	1000W	1000W	1500W	1500W
	TENSIONE DI ALIMENTAZIONE <i>MOTOR SUPPLY VOLTAGE</i>	12V	24V	12V	24V
	TIRO ISTANTANEO MASSIMO <i>MAXIMUM PULL</i>	1020 Kg	1060 Kg	1250 Kg	1290 Kg
	CARICO LAVORO AL SOLLEVAMENTO <i>LIFT WORKING LOAD</i>	130 Kg	140 Kg	150 Kg	160 Kg
	VELOCITÀ DI RECUPERO A CARICO <i>LINE SPEED</i>	25 mt/min	25 mt/min	26 mt/min	26 mt/min
	ASSORBIMENTO MEDIO <i>CURRENT ABSORPTION</i>	115 A	60 A	130 A	70 A
	PESO <i>WEIGHT</i>	11,5 Kg	11,5 Kg	11,8 Kg	11,8 Kg

1000	A	B	C	D	E	F	G	H
	138	80	126	30/52	114	150	250	80

1500	A	B	C	D	E	F	G	H
	138	80	126	30/52	114	150	250	80

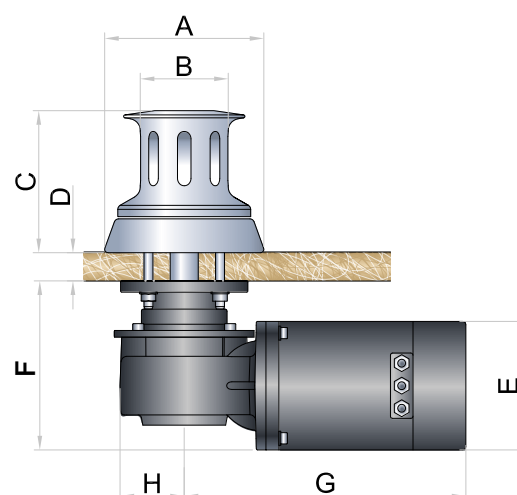

Tutte le misure indicate sono in mm  
All sizes are in mm



Il NESTOR-VX è il nuovo verricello da tonneggio in acciaio inox AISI 316, di facile installazione grazie al sistema EASY FIT è suggerito per barche fino ai 13m. Disponibile con motorizzazioni a 12V o 24V.

*NESTOR-VX is the new mooring winch in AISI 316 stainless steel. Easy to install thanks to the EASY FIT system is recommended for boats up to 13m. Available with 12V or 24V motors.*

### Innovativo sistema di fissaggio

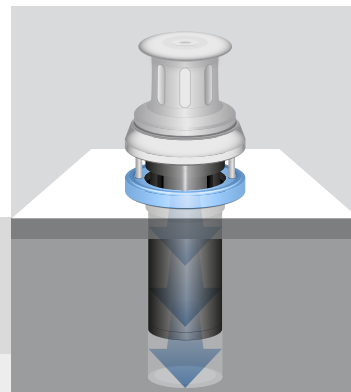

## EASYFIT

CARATTERISTICHE	POTENZA MOTORE <i>ELECTRIC MOTOR</i>	800W	800W
	TENSIONE DI ALIMENTAZIONE <i>MOTOR SUPPLY VOLTAGE</i>	12V	24V
	TIRO ISTANTANEO MASSIMO <i>MAXIMUM PULL</i>	800 Kg	810 Kg
	CARICO LAVORO AL SOLLEVAMENTO <i>LIFT WORKING LOAD</i>	100 Kg	100 Kg
	VELOCITÀ DI RECUPERO A CARICO <i>LINE SPEED</i>	25 mt/min	25 mt/min
	ASSORBIMENTO MEDIO <i>CURRENT ABSORPTION</i>	90 A	45 A
	PESO (CON CAMPANA) <i>WEIGHT (WITH DRUM)</i>	10,5 Kg	10,5 Kg

800	A	B	C	D	E
	118	145	20	237	78

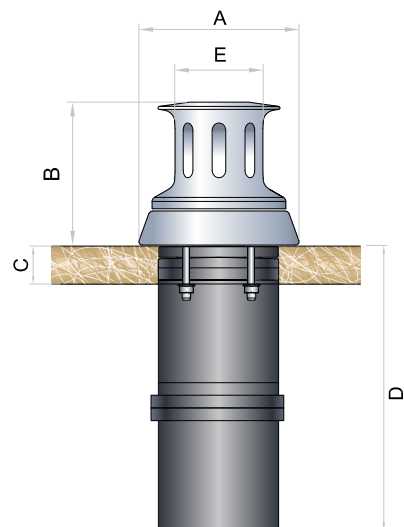

Verricello da tonneggio in acciaio inox AISI 316. Con differenti motorizzazioni è suggerito per barche fino ai 23m.

*Stainless steel AISI 316 capstan winch, with different drives and recommended for boats up to 23 meters.*



IDRAULICO



RELÉ



IP67

MOTOR

CARATTERISTICHE	POTENZA MOTORE <i>ELECTRIC MOTOR</i>							
	1500W	1500W	1700W	1700W	2000W	HY	2000W	
TENSIONE DI ALIMENTAZIONE <i>MOTOR SUPPLY VOLTAGE</i>	12V	24V	12V	24V	24V	N/A	230V/400V	
TIRO ISTANTANEO MASSIMO <i>MAXIMUM PULL</i>	1250 Kg	1290 Kg	1650 Kg	1700 Kg	1750 Kg	380 Kg	1700 Kg	
CARICO LAVORO AL SOLLEVAMENTO <i>LIFT WORKING LOAD</i>	150 Kg	160 Kg	220 Kg	240 Kg	270 Kg	380 Kg	250 Kg	
VELOCITÀ DI RECUPERO A CARICO <i>LINE SPEED</i>	26 mt/min	26 mt/min	26 mt/min	26 mt/min	12 mt/min	12 mt/min	12 mt/min	
ASSORBIMENTO MEDIO <i>CURRENT ABSORPTION</i>	130 A	70 A	185 A	90 A	100A	N/A	N/A	
PESO <i>WEIGHT</i>	18 Kg	18 Kg	23,1 Kg	23,1 Kg	24 Kg	21 Kg	25 Kg	

1500	A	B	C	D	E	F	G	H
	156	120	148	37/62	114	150	250	80

1700	A	B	C	D	E	F	G	H
	156	120	148	37/62	114	150	330	80

HY	A	B	C	D	E	F	G	H
	156	120	148	37/62	102	150	170	80

2000-DC	A	B	C	D	E	F	G	H
	156	120	148	37/62	114	150	330	80

2000-AC	A	B	C	D	E	F	G	H
	156	120	148	37/62	165	210	350	80

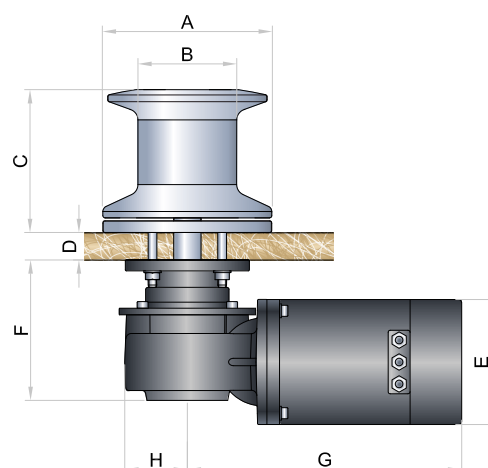

Tutte le misure indicate sono in mm  
All sizes are in mm

Verricello da tonneggio in acciaio inox AISI 316. Con differenti motorizzazioni è suggerito per barche fino ai 28m. Possibilità di avere la motorizzazione a 24V, 230V, 400V o idraulica.

*Stainless steel AISI 316 capstan winch, with different drives and recommended for boats up to 28 meters. Possibility of 24V, 230V, 400V or hydraulic drive*



CARATTERISTICHE	POTENZA MOTORE <i>ELECTRIC MOTOR</i>	2000W	2300W	2700W	2200W	3000W	HY
	TENSIONE DI ALIMENTAZIONE <i>MOTOR SUPPLY VOLTAGE</i>	24V	24V	24V	230V/400V	230V/400V	N/A
	TIRO ISTANTANEO MASSIMO <i>MAXIMUM PULL</i>	1750 Kg	2100 Kg	2300 Kg	2100 Kg	3000 Kg	1500 Kg
	CARICO LAVORO AL SOLLEVAMENTO <i>LIFT WORKING LOAD</i>	260 Kg	500 Kg	600 Kg	525 Kg	730 Kg	1500 Kg
	VELOCITÀ DI RECUPERO A CARICO <i>LINE SPEED</i>	12 mt/min	12 mt/min	12 mt/min	12 mt/min	18 mt/min	12 mt/min
	ASSORBIMENTO MEDIO <i>CURRENT ABSORPTION</i>	90 A	120 A	150 A	N/A	N/A	N/A
	PESO <i>WEIGHT</i>	←			40 to 55 Kg	→	

2000	A	B	C	D	E	F
	225	125	181	70/95	183	330

2300	A	B	C	D	E	F
	225	125	181	60/110	183	435

2700	A	B	C	D	E	F
	225	125	181	60/110	183	435

2200AC	A	B	C	D	E	F
	225	125	181	60/110	183	435

3600AC	A	B	C	D	E	F
	225	125	181	60/110	183	435

HY	A	B	C	D	E	F
	225	125	181	60/110	183	232

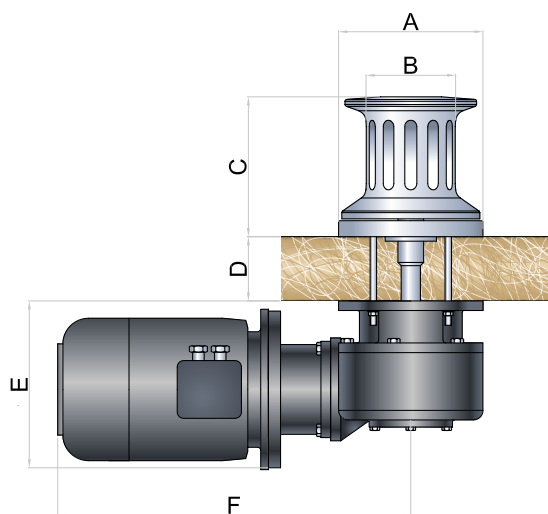

Tutte le misure indicate sono in mm  
All sizes are in mm



Verricello da tonneggio in acciaio inox AISI 316. Con differenti motorizzazioni è suggerito per barche fino ai 30m. Possibilità di avere la motorizzazione a 24V, 230V, 400V o idraulica.

*Stainless steel AISI 316 capstan winch, with different drives and recommended for boats up to 30 meters. Possibility of 24V, 230V, 400V or hydraulic drive*



CARATTERISTICHE	POTENZA MOTORE <i>ELECTRIC MOTOR</i>	2700W	2200W	HY
	TENSIONE DI ALIMENTAZIONE <i>MOTOR SUPPLY VOLTAGE</i>	24V	230V/400V	N/A
	TIRO ISTANTANEO MASSIMO <i>MAXIMUM PULL</i>	2300 Kg	2300 Kg	1500 Kg
	CARICO LAVORO AL SOLLEVAMENTO <i>LIFT WORKING LOAD</i>	600 Kg	625 Kg	1500 Kg
	VELOCITÀ DI RECUPERO A CARICO <i>LINE SPEED</i>	12 mt/min	12 mt/min	12 mt/min
	ASSORBIMENTO MEDIO <i>CURRENT ABSORPTION</i>	150 A	N/A	N/A
	PESO (CON CAMPANA) <i>WEIGHT (WITH DRUM)</i>	← 55 to 70 Kg →		

2700W	A	B	C	D	E	F
	225	140	218	50/110	180	395

2200W	A	B	C	D	E	F
	225	140	218	50/110	180	378

HY	A	B	C	D	E	F
	225	140	218	50/110	180	234

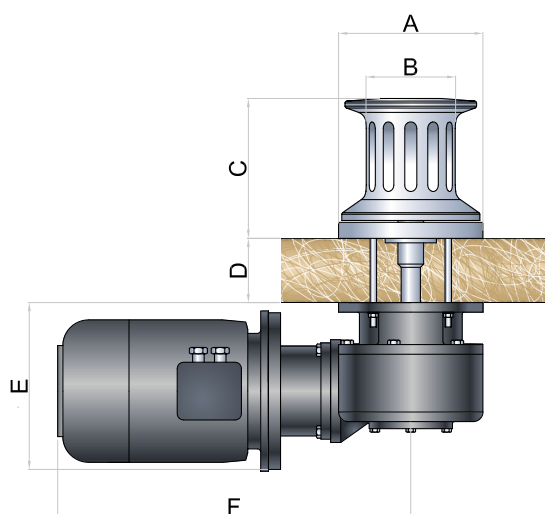

Tutte le misure indicate sono in mm  
All sizes are in mm

Verricello da tonneggio in acciaio inox AISI 316. Con differenti motorizzazioni è suggerito per barche fino ai 38m. Possibilità di avere la motorizzazione a 24V, 230V, 400V o idraulica.

*Stainless steel AISI 316 capstan winch, with different drives and recommended for boats up to 38 meters. Possibility of 24V, 230V, 400V or hydraulic drive*



CARATTERISTICHE	POTENZA MOTORE <i>ELECTRIC MOTOR</i>	3500W	3000W	4000W	HY
	TENSIONE DI ALIMENTAZIONE <i>MOTOR SUPPLY VOLTAGE</i>	24V	230V/400V	230V/400V	N/A
	TIRO ISTANTANEO MASSIMO <i>MAXIMUM PULL</i>	4000 Kg	4000 Kg	4500 Kg	1900 Kg
	CARICO LAVORO AL SOLLEVAMENTO <i>LIFT WORKING LOAD</i>	1100 Kg	1100 Kg	1300 Kg	1900 Kg
	VELOCITÀ DI RECUPERO A CARICO <i>LINE SPEED</i>	12 mt/min	12 mt/min	12 mt/min	12 mt/min
	ASSORBIMENTO MEDIO <i>CURRENT ABSORPTION</i>	195 A	N/A	N/A	N/A
	PESO (CON CAMPANA) <i>WEIGHT (WITH DRUM)</i>	← 60 to 80 Kg →			

3500	A	B	C	D	E	F
	225	140	218	130/170	263	562

3000AC	A	B	C	D	E	F
	225	140	218	130/170	263	675

4000AC	A	B	C	D	E	F
	225	140	218	130/170	263	600

HY	A	B	C	D	E	F
	225	140	218	130/170	263	450

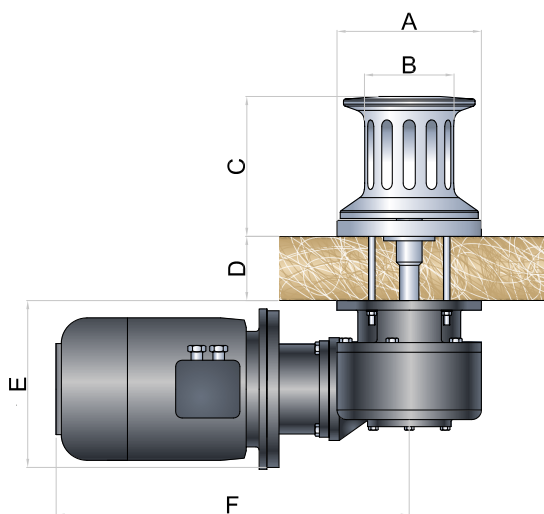

**OPTIONAL**  
CONFIGURAZIONE COASSIALE  
COAXIAL CONFIGURATION

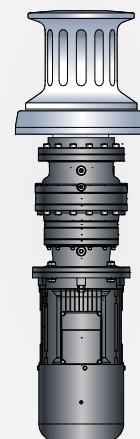

Tutte le misure indicate sono in mm  
All sizes are in mm



Verricello da tonneggio in acciaio inox AISI 316. Con differenti motorizzazioni è suggerito per barche fino ai 50m. Possibilità di avere la motorizzazione a 230V, 400V o idraulica.

*Stainless steel AISI 316 capstan winch, with different drives and recommended for boats up to 50m. Possibility of 230V, 400V or hydraulic drive*



IDRAULICO

CARATTERISTICHE	POTENZA MOTORE <i>ELECTRIC MOTOR</i>	3500W	3000W	4000W	HY1
	TENSIONE DI ALIMENTAZIONE <i>MOTOR SUPPLY VOLTAGE</i>	24V	230V/400V	230V/400V	N/A
	TIRO ISTANTANEO MASSIMO <i>MAXIMUM PULL</i>	3000 Kg	3100 Kg	4200 Kg	3000 Kg
	CARICO LAVORO AL SOLLEVAMENTO <i>LIFT WORKING LOAD</i>	1100 Kg	1250 Kg	1700 Kg	3000 Kg
	VELOCITÀ DI RECUPERO A CARICO <i>LINE SPEED</i>	13 mt/min	12 mt/min	12 mt/min	12 mt/min
PESO <i>WEIGHT</i>	← 140 to 190 Kg →				

3500DC	A	B	C	D	E	F
	330	180	316	120/170	470	528

3000AC	A	B	C	D	E	F
	330	180	316	max150	550	627

4000AC	A	B	C	D	E	F
	330	180	316	max150	550	651

HY1	A	B	C	D	E	F
	330	180	316	max150	550	365

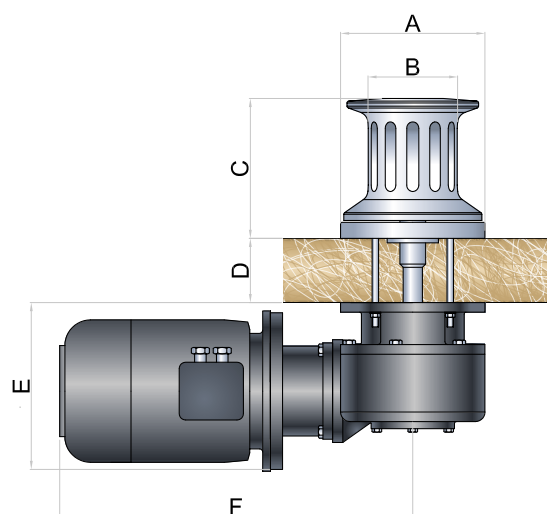

Tutte le misure indicate sono in mm  
All sizes are in mm

# NC-360, NC-440, NC-500

CAPSTANS



Verricello da tonneggio in acciaio inox AISI 316. Con differenti motorizzazioni è suggerito per barche fino ai 80m. Possibilità di avere la motorizzazione a 230V, 400V o idraulica.

*Stainless steel AISI 316 capstan winch, with different drives and recommended for boats up to 100m. Possibility of 230V, 400V or hydraulic drive*



IDRAULICO

CARATTERISTICHE	POTENZA MOTORE <i>ELECTRIC MOTOR</i>	7500W	9200W	11000W	15000W	18500W	HY1	HY2
	TENSIONE DI ALIMENTAZIONE <i>MOTOR SUPPLY VOLTAGE</i>	230V/400V	230V/400V	230V/400V	230V/400V	230V/400V	N/A	N/A
	TIRO ISTANTANEO MASSIMO <i>MAXIMUM PULL</i>	7075 Kg	9056 Kg	10827 Kg	14765 Kg	15866 Kg	4528 Kg	9425 Kg
	CARICO LAVORO AL SOLLEVAMENTO <i>LIFT WORKING LOAD</i>	3537 Kg	4528 Kg	5413 Kg	7382 Kg	7933 Kg	4528 Kg	9425 Kg
	VELOCITÀ DI RECUPERO A CARICO <i>LINE SPEED</i>	12 mt/min	12 mt/min	12 mt/min	12 mt/min	13 mt/min	12 mt/min	13 mt/min

NC-360	A	B	C	D	E	F
	360	230	310	MIN235	457	735

NC-440	A	B	C	D	E	F
	440	290	385	MIN300	511	830

NC-500	A	B	C	D	E	F
	500	400	440	MIN400	540	900

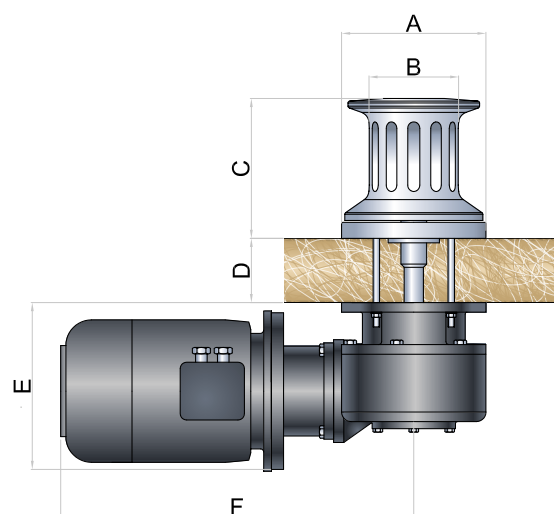

Tutte le misure indicate sono in mm  
All sizes are in mm



## OPTIONAL



**MOTORE A DOPPIA VELOCITÀ**  
DOUBLE SPEED MOTOR



**FRENO  
ELETTROMAGNETICO**  
MAGNETIC BRAKE



**Configurazione ortogonale**  
*Orthogonal configuration*

**Configurazione coassiale**  
*Coaxial configuration*

**Motore idraulico**  
*Hydraulic drive*

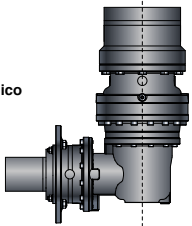

**Motore elettrico (CA)**  
*Electric drive (AC)*

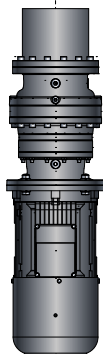
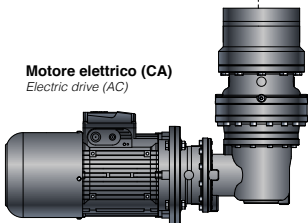

**Motore elettrico (CA)**  
*Electric drive (AC)*

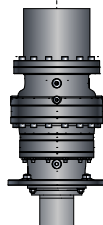

**Motore idraulico**  
*Hydraulic drive*



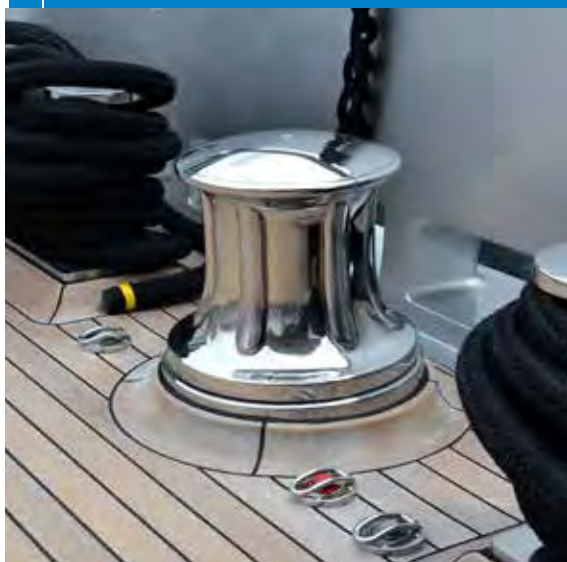

Verricello da tonneggio in acciaio inox AISI 316. Con differenti motorizzazioni è suggerito per barche fino ai 100m. Possibilità di avere la motorizzazione a 230V, 400V o idraulica.

*Stainless steel AISI 316 capstan winch, with different drives and recommended for boats up to 100m. Possibility of 230V, 400V or hydraulic drive*



IDRAULICO

CARATTERISTICHE	POTENZA MOTORE <i>ELECTRIC MOTOR</i>	18500W	22000W	HY2
	TENSIONE DI ALIMENTAZIONE <i>MOTOR SUPPLY VOLTAGE</i>	230V/400V	230V/400V	N/A
	TIRO ISTANTANEO MASSIMO <i>MAXIMUM PULL</i>	15866 Kg	18851 Kg	9425 Kg
	CARICO LAVORO AL SOLLEVAMENTO <i>LIFT WORKING LOAD</i>	7933 Kg	9425 Kg	9425 Kg
	VELOCITÀ DI RECUPERO A CARICO <i>LINE SPEED</i>	13 mt/min	13 mt/min	13 mt/min

NC-560	A	B	C	D	E	F
	560	470	460	MIN500	560	1060

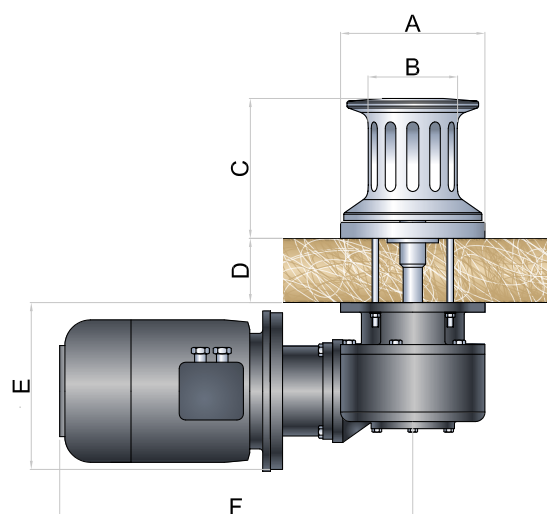

Tutte le misure indicate sono in mm  
All sizes are in mm

**ACCESSORI**  
ACCESSORIES



# Guida Blocca Catena Standard

ACCESSORIES

STANDARD CHAIN STOPPER

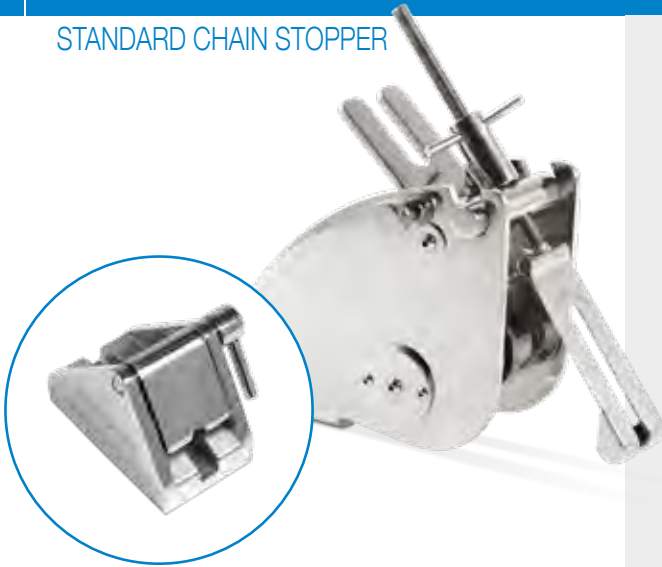

Italwinch dispone di quattro modelli standard di guida blocca catena compatibili con le principali catene a partire da 8mm di diametro fino a 17,5mm. Questi modelli sono forniti di serie con il tendi catena sono realizzati totalmente in acciaio inox AISI 316L.

*Italwinch has four standard models of chain stopper with roller suitable for the main chains from 8mm of diameter up to 17.5 mm. These models come standard with a chain tensioner ("devil claw") and are completely made in stainless steel AISI 316L.*



STP-10X	Barbotin / Gipsy	8mm				10mm		10 DIN 766			
	Catena supportata Chain supported	8mm ISO	8mm DIN766	5/16" G4	5/16" BBB	10mm ISO	3/8" G4	10mm DIN766	3/8" BBB		
STP-12	Barbotin / Gipsy	12mm			13DIN764	14mm	12,5 C.T.	14 C.T.	1/2"BBB	1/2" HT	
	Catena supportata Chain supported	12mm ISO	13mm DIN 766	7/16" G4	13mm DIN764	14mm ISO	12,5 Stud link	14 Stud link	1/2" BBB	1/2" HT	
MOD-16	Barbotin / Gipsy	12mm			13DIN764	14mm	12,5 C.T.	14 C.T.	1/2" HT		
	Catena supportata Chain supported	12mm ISO	13mm DIN 766	7/16" G4	13mm DIN764	14mm ISO	12,5 Stud link	14 Stud link	1/2" HT		
MOD-17	Barbotin / Gipsy	12,5 C.T.	14 C.T.	16mm	16DIN766	16 C.T.	17,5 C.T.				
	Catena supportata Chain supported	12,5 Stud link	14 Stud link	16mm ISO	16mm DIN766	16 Stud link	17,5 Stud link				

STP-10X

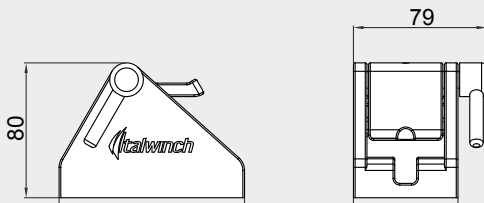

MOD-16

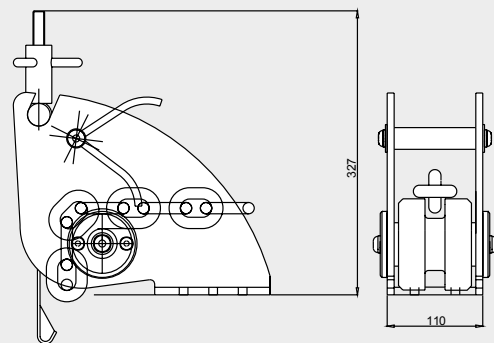

STP-12

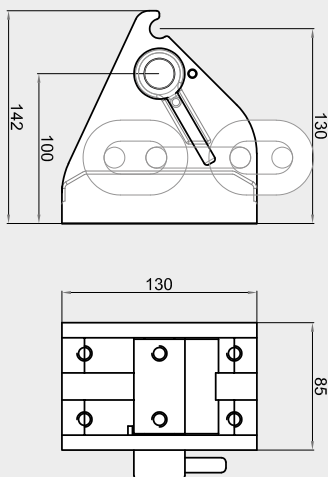

MOD-17

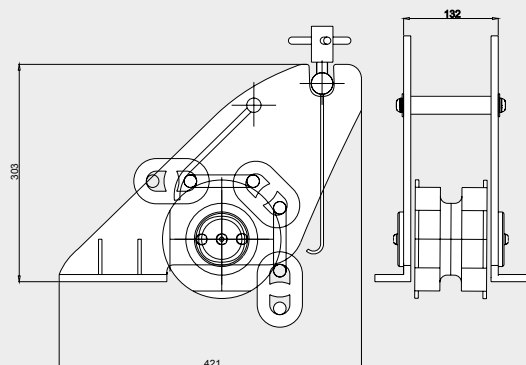



# Guida Blocca Catena Custom

ACCESSORIES

## CUSTOM CHAIN STOPPER WITH ROLLER

**Guida blocca catena**  
Chain stopper with roller

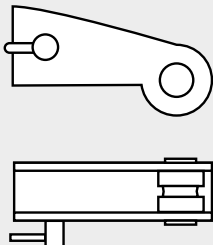

**Guida blocca catena con volantino**  
Chain stopper with roller and tensioner

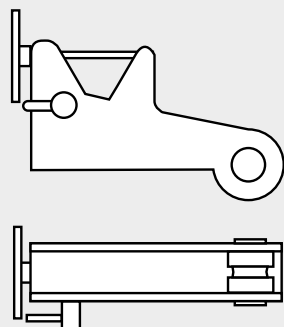

Italwinch propone una vasta gamma di accessori per il verricello: guida blocca catena con rullo e artiglio integrato, blocca catena, "chain compressor" o semplici rulli. Tutti questi modelli sono realizzati in acciaio inox AISI 316L e sono personalizzabili in base alle esigenze del cliente. Disponibili per verricelli orizzontali o verticali per catene fino a 32mm di diametro e certificabili con i principali enti certificatori.

*Italwinch supply a wide range of accessories for the windlass: different models of bow roller with chain stopper and claw integrated, chain compressor, only chain stopper or chain rollers. All these models are made in AISI 316L stainless steel and can be custom made under the requests of the customer. Available for vertical or horizontal windlasses with chain up to 32mm of diameter and certifiable with the major certification authorities.*

**Occhio di cubia con rullo**  
Chain Pipe - with roller

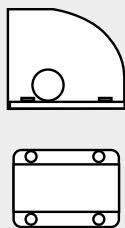

**Compressor**  
Chain Compressor

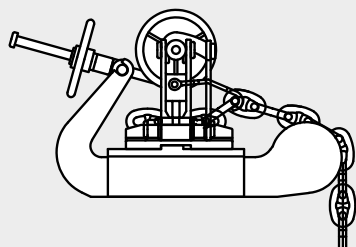

**Guida blocca catena con volantino**  
Chain stopper with roller and tensioner

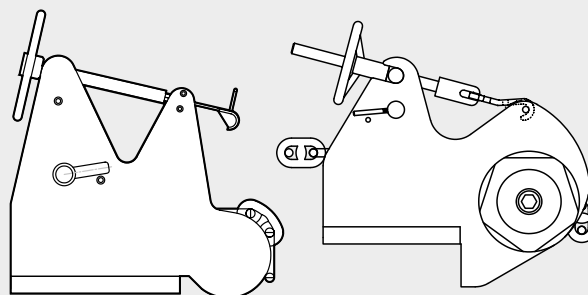

# WHC040 Radio contametri e comando eliche di manovra

ACCESSORIES

Radio chain counter and thruster control



WHC040 Il radio-contametri WHC040 è un innovativo strumento che permette il comando del salpa ancora tramite una pulsantiera radio, che fornisce anche la misura della catena calata. Inoltre è predisposto per poter comandare anche l'elica di prua e l'elica di poppa (se presenti). La versione WHC040-VER permette di gestire solo il salpa ancora.

- Tensione di alimentazione: 10...32V DC/AC
- Grado di protezione: IP67
- Batteria interna agli ioni di litio ricaricabile wireless (caricabatterie incluso)
- Indicazioni sul display in 5 lingue
- Funzione di discesa automatica
- Funzione di allarme salita
- Funzione di blocco della tastiera per prevenire azionamenti accidentali
- Visualizzazione della velocità della catena

*The WHC040 radio chain-counter is an innovative instrument that allows the windlass to be controlled via a radio hand control, which also provides the measurement of the lowered chain. It is also designed to be able to control the bow thruster and the stern thruster (if present). The WHC040-VER version allows you to manage only the windlass.*

- Receiver supply voltage: 10...32V DC/AC
- IP degree: IP67
- Internal wireless rechargeable lithium ion battery (charger included)
- 5 languages display
- Automatic descent function
- Up alert function
- Keyboard block function to prevent accidental activation
- Chain speed display

# HC020 Pulsantiera Contametri

ACCESSORIES

Hand held control chain counter



Il contametri HC020 nasce dalla grande esperienza MZ Electronic in questo settore. Con il nuovo ampio display permette di controllare il salpa ancora in tutte le sue funzionalità, fornendo anche la misura della catena calata.

- Tensione di alimentazione: 10...32V DC/AC
- Grado di protezione: IP67
- Indicazioni sul display in 5 lingue
- Funzione di discesa automatica
- Funzione di Allarme salita.
- Funzione di blocco della tastiera per prevenire azionamenti accidentali
- Visualizzazione della velocità della catena
- Staffa di supporto per riporla dopo l'utilizzo

*The HC020 chain-counter is the result of MZ Electronic's great experience in this sector. With the new large display it allows you to control the windlass in all its functions, also providing the size of the chain lowered.*

- Supply voltage: 10...32V DC/AC
- IP degree: IP67
- 5 languages display
- Automatic descent function
- Up alert function
- Keyboard block function to prevent accidental activation
- Chain speed display
- Support bracketed for stowing after use

# EV030 Radio

ACCESSORIES

## REMOTE CHAIN COUNTER



VOLTS

Questo radiocontametri unisce all'eleganza della linea evolution, la praticità dei collegamenti. Il ricevitore viene facilmente installato sotto coperta, accanto al sensore magnetico. Lo strumento viene collegato in plancia, senza bisogno di collegare nient'altro che l'alimentazione.

**FREQUENZA DI LAVORO 868 MHz**

*This radio chain counter offers the elegance of Evolution line and practice connections. The receiver is easily mounted near magnetic sensor and the instrument is mounted on flybridge connecting only the battery and nothing else.*

**WORKING FREQUENCY 868 MHz**



L 100 mm x H 100 mm x P 32 mm

# EV030

ACCESSORIES

## CHAIN COUNTER



VOLTS

Compatto, dal design elegante e funzionale, il contametri ev030 si adatta ad ogni plancia e ad ogni verricello e permette di avere sempre sotto controllo le manovre di ancoraggio dalla postazione di comando.

*Compact, with elegant and functional design, it's perfect for every flybridge and every winch in commerce. In order to have always under control the anchorage manouuvres.*



L 100 mm x H 100 mm x P 32 mm

### CARATTERISTICHE TECNICHE DEI CONTAMETRI:

- Indicazioni in 5 lingue
- Utilizzo semplice e immediato
- Allarme di risalita
- Discesa automatica della catena
- Visualizzazione della velocità di manovra
- Visualizzazione tensione alimentazione del verricello
- Possibile scelta tra metri o piedi come unità di misura
- Display LCD grafico ad elevata risoluzione
- Illuminazione display regolabile
- Contrasto display regolabile
- Contenitori/gusci impermeabili IP 56

### SOLO PER EV040

- Radiocomando ricaricabile con presa accendisigari
- Visualizzazione stato di carica del radiocomando

### TECHNICAL CHARACTERISTICS OF THE CHAIN COUNTER:

- Indications in 5 languages
- Simple and immediate use
- Up alarm function
- Automatic descent function
- Display of the manoeuvres speed
- Display of the power supply voltage of the motor
- Choice between meters or feet as unit of measure
- High resolution LCD display
- Adjustable Lighting system display
- Adjustable Contrast display
- Universal Feeding (12-24V)
- Watertight case IP 56

### ONLY FOR EV040

- Rechargeable radio control with cigarette lighter
- Display of the charge level of the radio unit



**NAUTI001 (OPTIONAL)**

**KIT SENSORE MAGNETE PER CONTAMETRI**

**SENSOR AND MAGNET KIT FOR CHAIN COUNTER**





## Chaincounter & Thruster Controller

MZ-LINK è un dispositivo innovativo, che permette di integrare i prodotti MZ a quelli di navigazione; è in grado di ricevere i dati, ri-elaborarli per poi inviarli al plotter. MZ-LINK permette di controllare verricelli, contametri e thruster sui principali chart plotter disponibili sul mercato. È possibile personalizzare la grafica, scegliere la tipologia di imbarcazione ed impostare alcuni parametri per la gestione ottimale dell'ormeggio. Risultano infatti molto utili alcune funzioni quali la rotazione e la traslazione dell'imbarcazione per gestire al meglio le manovre nel porto o l'impostazione automatica di calata catena con la metratura preimpostata.



*MZ-LINK is an innovative device that allows MZ products to be integrated with chart plotter systems; it is able to receive the data, elaborate them and then send them to the plotter. MZ-LINK allows you to control winches, chain counter and thrusters on the main chart plotters available on the market. It is possible to customize the graphics, choose the type of boat and set some parameters for optimal mooring management. In fact, some functions are very useful such as the rotation and translation of the boat to better manage the maneuvers in the harbor or the automatic setting of the chain lowering with the preset length.*





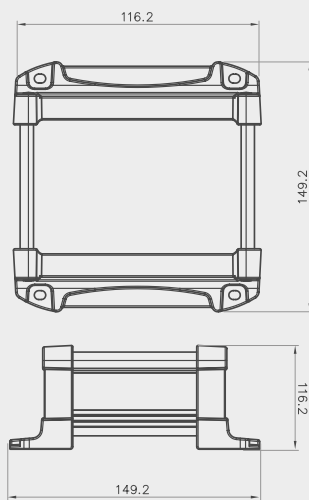

Caratteristiche:

- Comando di salita e discesa per salpa ancora (fino a 2 configurabili)
- Visualizzazione metri calati fino a due salpa ancora
- Funzione discesa automatica per salpa ancora
- Modalità tonneggio
- Possibilità di comandare sia elica di prua che di poppa
- Opzione di rotazione e traslazione dell'imbarcazione

Main features:

- *Up and down command for anchor windlass (up to 2 configurable)*
- *Chain counter display up to two windlasses*
- *Automatic descent function for anchor windlass*
- *Warping head mode*
- *Possibility of controlling both bow and stern thrusters*
- *Boat rotation and translation option*



# Contametri da plancia

ACCESSORIES

CHAIN COUNTER



CC011

Il contametri CC011 è slim e compatto, ottimo per essere installato su sistemi che già dispongono di comandi per il verricello, ma non possiedono un contacatena. Facile da installare e compatibile con ogni tipo di verricello in commercio, può visualizzare la misura di catena calata in metri o piedi.

Il prodotto ha la sola funzione di contametri, non comanda il salpa ancora.

Caratteristiche:

- Alimentazione 12/24VDC
- Display grafico retroilluminato 1.54" da 240x240 pixel
- Superficie in vetro temperato con pulsanti capacitivi
- Misura da 0 a 999 (metri o piedi)
- Impostazione in lingua italiano/inglese/francese/tedesco/spagnolo
- Modalità di funzionamento in grafica bianca o nera (selezionabile)
- Diametro x Lunghezza = 65 x 60mm

*The CC011 chain counter is slim and compact, perfect for installation on systems that already have winch controls, but do not have a chain counter. Easy to install and compatible with any type of winch on the market, it can display the measurement of the chain lowered in meters or feet.*

*The product can only work as meter counter, it does not control the windlass.*

Characteristics:

- 12/24VDC power supply
- 1.54inch, 240x240 pixels, backlit graphic display
- Tempered glass surface with capacitive buttons
- Measure from 0 to 999 (meters or feet)
- Setting in Italian/English/French/German/Spanish
- Mode of operation in white or black graphics (selectable)
- Diameter x Length = 65 x 60mm



L 65 mm x H 65 mm x P 60 mm

# Comando per salpa ancora

ACCESSORIES

ANCOR WINDLASSES CONTROL



COM.UPDOWN\_BL

Dispositivo elettrico che consente di azionare il salpa ancora in zona timone. (UP/DOWN)

*Windlass control board. Electric device enabling windlass operation even in the rudder-area. (UP/DOWN)*



L47 mm x H 75 mm

# KOMPASS Radiocomandi

ACCESSORIES

REMOTE CONTROL UNITS



Ricevitore  
Receiver

Antenna Remota  
Remota Antenne  
(Optional)

I radiocomandi MZ permettono, come le pulsantiere, l'utilizzo di salpancora, eliche di manovra, gruette e passerelle privilegiando la praticità grazie ad un comando senza fili, maneggevole e comodo. Disponibili a 2 e 4 canali di comando, con ricevitore e trasmettitore stagno IP66. Modalità di frequenza 433Mhz o 868Mhz.

*Just like the remote control units, the MZ radio control units can command anchor Winches, bow & stern thrusters, crabs and gangways and are easy to use thanks to the handy remote control feature. Available in 2 and 4 channels, with an IP66 watertight receiver and transmitter. Frequency band: 433 Mhz or 868Mhz.*



**TX** • L 52 mm x H 98 mm x P 26 mm  
**RX** • L 150 mm x H 57 mm x P 32 mm

<b>KOMPASS 2</b>	2 canali / 2 channels	433,92 MHz
<b>KOMPASS 4</b>	4 canali / 4 channels	433,92 MHz
<b>KOMPASS 2 868</b>	2 canali / 2 channels	868 MHz
<b>KOMPASS 4 868</b>	4 canali / 4 channels	868 MHz

# Radiocomando KOMPASS-8

ACCESSORIES

KOMPASS-8 RADIO CONTROL



Ricevitore  
Receiver

Antenna Remota  
Remota Antenne  
(Optional)

Il radiocomando Kompass-8 permette di gestire fino ad 8 canali di trasmissione e quindi manovrare due verricelli e due eliche di manovra. Con il tasto di scelta rapida è possibile anche azionare contemporaneamente due eliche di manovra, rendendo ancora più facile l'ormeggio. Trasmettitore galleggiante IP67. Modalità di frequenza 868Mhz o 915Mhz.

*The Kompass-8 remote control can handle up to 8 channels of transmission operating two winches and the bow and stern thrusters. With the shortcut key is also possible to operate simultaneously two thrusters, making even easier the mooring. Floating transmitter IP67. Attendance 868Mhz or 915Mhz.*



L 60 mm x H 145 mm x P 30 mm

# STORM Radiocomandi

ACCESSORIES

STORM-6 STORM-8 RADIO CONTROL



I radiocomandi Storm-6 e Storm-8 permettono di gestire fino a 8 canali di trasmissione. Modalità di frequenza 2400 Mhz, alimentazione della centralina 12-24V. Ideale per un utilizzo a lungo raggio permette di gestire applicazioni complesse come gruette e passerelle.

*The Storm-6 and Storm-8 remote controls can handle up to 8 transmission channels. Attendance 2400 Mhz, 12-24V transmitter supply. Ideal for long-range use, it allows the management of complex applications such as crabs and gangways.*



L 65 mm x H 110 mm x P 24 mm

## HAND HELD CONTROL

**HC200**

2 Canali 2 Channels



**HC300**

3 Canali 3 Channels



**HC400**

4 Canali 4 Channels



**HC600**

6 Canali 6 Channels



Le pulsantiere della gamma HC permettono la gestione di salpa ancora, gruette, passerelle fino a 6 movimenti.

- Tensione di alimentazione: 10...32V DC/AC
- Grado di protezione: IP67
- Cavo estensibile fino a 4m
- Staffa di supporto per riporla dopo l'utilizzo

The Hand held controls of the HC range allow the management of anchor winches, davits, gangways, etc. up to 6 movements.

- Supply voltage: 10...32V DC/AC
- IP degree: IP67
- Extensible cable up to 4m
- Support bracked for stowing after use



**POWER SUPPLY (12-24V)**



**IMPACT-PROOF**



**WATER-PROOF**

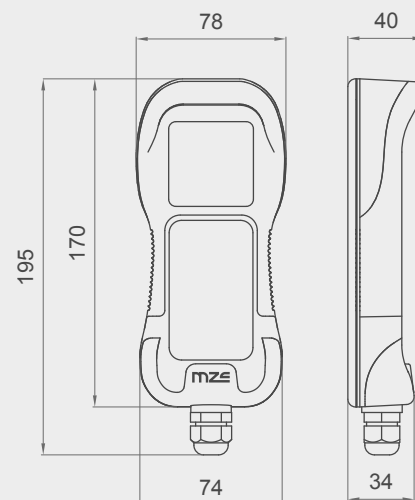



# Comandi a piede

ELECTRIC FOOT SWITCHES

ACCESSORIES

Pulsante a perfetta tenuta stagna, creato per azionare con la pressione del piede il comando di relé o altri carichi. Portata massima: 4 A. Base in acciaio inox. Dotato di coperchio di chiusura in materiale termoplastico antiurto per evitare azionamenti involontari. Pulsante di comando in gomma siliconica resistente all'acqua di mare. Disponibile nei colori bianco, grigio e acciaio inossidabile.

*Perfectly watertight control for relays or other loads, which can be activated by the simple pressure of your foot. Perfect watertight execution - Max. loading: 4 A. Inox steel base. Fitted with a hinged thermoplastic crashproof flap cover in order to avoid fortuitous operation. Control button in sea water resistant silicon rubber. Available in grey, white or stainless steel.*



**FOSWI110-AISI (INOX DOWN)**  
**FOSWI120-AISI (INOX UP)**  
**FOSWI130-AISI (INOX WASH)**



L 79 mm  
H 20 mm  
P 90 mm



**FOSWI110BIS (BIANCO DOWN)**  
**FOSWI120BIS (BIANCO UP)**  
**FOSWI130BIS (BIANCO WASH)**



L 79 mm  
H 17 mm  
P 90 mm



**FOSWI210BIS (GRIGIO DOWN)**  
**FOSWI220BIS (GRIGIO UP)**  
**FOSWI230BIS (GRIGIO WASH)**



L 79 mm  
H 17 mm  
P 90 mm



**FOSWI210\_ONN (INOX DOWN)**  
**FOSWI220\_ONN (INOX UP)**  
**FOSWI230\_ONN (INOX WASH)**



L 97 mm  
H 28 mm  
P 97 mm



VOLTS

I contattori e gli invertitori MZ sono apparecchiature di comando per motori in CC a 2, 3 o 4 fili. Grazie al gruppo pre assemblato, i collegamenti elettrici sono pratici e veloci. Disponibili in diverse tipologie per soddisfare ogni tipo di esigenza, per alimentazione da 10 a 30 VCC a basso consumo, i contattori resistono agli urti ed alla corrosione marina, grazie alla loro custodia in resina poliesteri autostinguente, con grado di protezione IP 56.

*The MZ contactors and inverters are control devices for 2, 3 or 4 wires DC motors. The pre-assembled group makes electrical connections quick and easy. Available in different versions to meet any requirement, and low consumption powering from 10 to 30 VDC, the contactors are shockproof and resistant to marine corrosion thanks to their IP 56 self-extinguishing polyester resin casing.*



**MZ2090/L**  
**MZ2090/O**  
**MZ2130/H**  
**MZ2130/I**



**MZ2100/M**  
**MZ2150/C**  
**MZ2150/D**  
**MZ2150PA/C**  
**MZ2150PA/D**



**MZIC20133**  
**MZIC20134**



**MZIC20123**

DESCRIPTION	COIL	D.C. AMP	MOTOR W	WEIGHT	SIZE
bipolar inverter	12V	90A	700W	0,7Kg	1
bipolar inverter	24V	110A	700W	0,7KG	2
bipolar inverter	12V	130A	1300w	1,1 Kg	4
bipolar inverter	24V	100A	1300w	1,1 Kg	4

DESCRIPTION	COIL	D.C. AMP	MOTOR W	WEIGHT	SIZE
bipolar contactor	12V	100A	700w	0,7 Kg	3
bipolar contactor	12V	150A	1700w	1,1 Kg	4
bipolar contactor	24V	130A	1700w	1,1 Kg	4
bipolar contactor	12V	200A	2000w	1,1 Kg	4
bipolar contactor	24V	180A	2000w	1,1 Kg	4

DESCRIPTION	COIL	D.C. AMP	MOTOR W	WEIGHT	SIZE
bipolar inverter	12V	225A	3000w	1,4 Kg	5
bipolar inverter	24V	250A	3000w	1,4 Kg	5

DESCRIPTION	COIL	D.C. AMP	MOTOR W	WEIGHT	SIZE
bipolar inverter	24V	360A	3500w	3,1 Kg	6

Tutte le misure indicate sono in mm  
All sizes are in mm



**MZ0180/G**  
**MZ0180/F**



**MZ0250/G**  
**MZ0250/F**

DESCRIPTION	COIL	D.C. AMP	MOTOR W	WEIGHT	SIZE
unipolar contactor	24V	180A	2000w	0,5 Kg	B1
unipolar contactor	12V	200A	2000w	0,5 Kg	B1

DESCRIPTION	COIL	D.C. AMP	MOTOR W	WEIGHT	SIZE
unipolar contactor	24V	230A	3000w	1 Kg	B2
unipolar contactor	12V	250A	3000w	1 Kg	B2

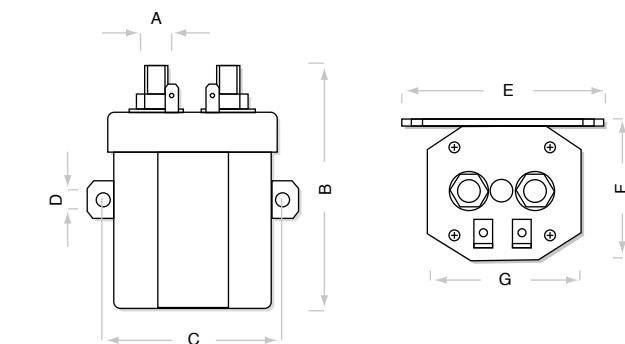
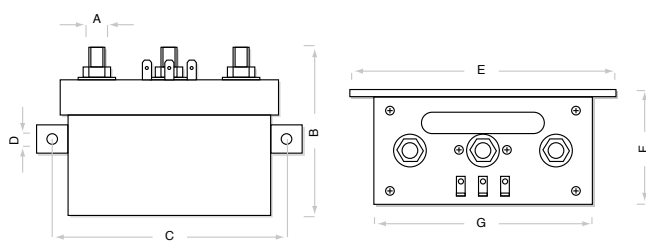

	A	B	C	D	E	F	G
1	6	74	68	5	8	51	68
2	6	84	73	5	8	49	66
3	8	88	100	4,5	113	55	92
4	8	95	115	7	129	68	114
5	8	120	107	7	126	72	91
6	10	153	131	7	156	65	116

	A	B	C	D	E	F	G
B1	8	93	67	4,5	78	54	60
B2	10	188	73	07	102	48	66

Un utile complemento ai relé MZ a 12V è l'adattatore MZ1030/S, che consente di alimentare un qualsiasi contattore unipolare a 12V, con tensioni da 10 a 30 V, permettendo così di ridurre la corrente assorbita dalla bobina fino al 70% del valore normale.

*The MZ1030/S adapter is a useful addition to 12V MZ unipolar contactors as it can power any 12V relay from 10 to 30V, hence reducing the current absorbed by the coil, up to 70% of the rated value.*



**COIL ENERGY SAVER - MZ1030/S**

**only for MZ0180/F**



L 34 mm x H 34 mm x P 18 mm

Tutte le misure indicate sono in mm  
All sizes are in mm

## AC CONTROL BOXES



**Quadri elettrici di controllo che coprono l'intera gamma di verricelli salpa ancora Italwinch. Di seguito le varie caratteristiche di queste cassette:**

- **possibilità di realizzare cassette su misura**
- **diverse colorazione disponibili**
- **alimentazioni disponibili: 110V, 230V o 400V (mono-fase o trifase)**
- **frequenze supportate: 50Hz o 60Hz**
- **potenza massima: 20 KW**
- **possibilità di realizzazione con SOFT START**
- **gestione opzionale tramite INVERTER con potenziometro per la regolazione della velocità di risalita**
- **gestione della salita e discesa, comando per lavaggio catena e pulsante per stop d'emergenza**
- **possibilità d'integrazione del contametri**

*Control boxes that cover the entire range of Italwinch windlass. Here are the various features of these boxes:*



- *possibility of making customized boxes*
- *different colours available*
- *available power supplies: 110V, 230V or 400V (single phase or three-phase)*
- *supported frequencies: 50Hz or 60Hz*
- *maximum power: 20 KW*
- *SOFT START management option*
- *INVERTER management option with potentiometer for the regulation of the speed*
- *up and down chain management, chain washing command and emergency button*
- *possibility of chain-counter integration*



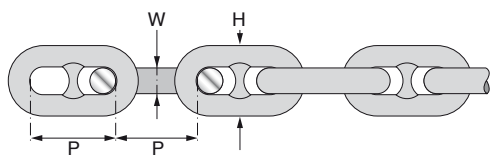
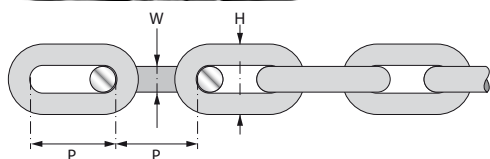

La scelta della giusta catena per l'ormeggio o il traino navale è importante per garantire sicurezza e affidabilità. Una catena di buona qualità e della giusta dimensione garantisce una presa sicura sull'ancora, resistenza alle sollecitazioni e alla corrosione, e una durata maggiore. La nostra esperienza nel campo dell'ormeggio ci permette di avere contatti con i migliori produttori ed ottenere le certificazioni delle nostre catene da tutti gli enti IACS da tutti i registri navali e fluviali nazionali e internazionali.

*Choosing the right chain for mooring or naval towing is important to ensure safety and reliability. A high-quality chain of the right size guarantees a secure grip on the anchor, resistance to stress and corrosion, and a longer lifespan. Our experience in mooring allows us to have contacts with the best producers and we can have our chains certified by all IACS entities and all national and international naval and river registers.*

**Catene calibrate** zincate a fuoco o in acciaio Inox AISI 316.  
*Calibrated hot dipped galvanized or stainless steel AISI 316 chains*

Diametro/Diameter (W)	Tipo/Type	Passo/Pitch (P)	Altezza/Height (H)	Peso/Weight	
mm		mm	mm	kg/m	lb/m
6	DIN766	18,5	20	0,8	1,77
7	DIN766	22	23	1,1	2,45
8	DIN766	24	26	1,4	3,00
10	DIN766	28	34	2,3	5,00
10	ISO 4565	30	35	2,4	5,20
12	ISO 4565	36	40	3,0	6,70
13	DIN766	36	44	3,9	8,60
14	ISO 4565	42	47	4,4	9,70
16	ISO 4565	48	54	5,7	12,50
16	DIN 766	45	54	5,7	12,50
18	ISO 4565	54	59	7,8	16,90
20	ISO 4565	60	66	9,3	20,00

**Catene con traversino** zincate a fuoco  
*Stud Link Calibrated hot dipped galvanized chains*

Diametro/Diameter (W)	Tipo/Type	Passo/Pitch (P)	Altezza/Height (H)	Peso/Weight	
mm		mm	mm	kg/m	lb/m
12,5	STUD LINK	50	45	4,0	8,81
14	STUD LINK	56	50	4,7	10,30
16	STUD LINK	64	58	6,2	13,67
17,5	STUD LINK	70	63	6,9	15,20
19	STUD LINK	76	68	8,2	18,00
20,5	STUD LINK	82	74	9,5	21,00
22	STUD LINK	88	79	11	24,30
24	STUD LINK	96	86	12,9	38,43
26	STUD LINK	104	94	15,2	33,51
28	STUD LINK	112	101	17,8	39,24



I regolatori di velocità MZ tipo RPWM consentono di regolare la velocità dei motori in modo continuo da zero al 100%. Possono essere usati per motori a 2 fili a magneti permanenti o per motori avvolti. Consentendo un avviamento dolce e graduale non sollecitano le batterie e ne prolungano la durata. Sono disponibili in tre taglie di potenza, comandabili da un pannello di controllo, o da pulsantiera elettronica o da un pannello a joystick. Tutte le unità RPWM sono dotate di allarmi visivi e sonori contro il sovraccarico, la sovratemperatura, e delle anomalie di funzionamento riscontrate.

*The MZ RPWM speed controllers will allow you to regulate the engine speed from 0 to 100% in a continuous way. MZ RPWM can be used for both permanent magnet two-wires engines and wound engines. The RPWM speed controllers allow a soft and gradual start of the engine so that they do not stress batteries and will extend their lifetime. RPWM are available in three power sizes that you can command whether by a control panel, electronic hand-held controls or a joystick panel. All the RPWM units are equipped with visual and sound alarms in order to prevent overload, overheating and other possible operating anomalies.*



RPWM-PA1

pannello controllo per box RPWM001

RPWM-PA2

pannello controllo per box RPWM002 - RPWM003  
Box panel control

RPWM-PU2

pulsantiera per box RPWM002 - RPWM003  
Box hand-held control

	POTENZA	TIPO MOTORE	ALIM.	INV. ROT.	DIMENSIONI
RPWM001-12	400 W	12VDC 2 FILI	12VDC	NO	175x150x80mm
RPWM001-24	700 W	24VDC 2 FILI	24VDC	NO	175x150x80mm
RPWM002	1500 W	12VDC 2 o 3 FILI	10..28V	SI	275x225x120mm
	2200 W	12VDC 2 o 3 FILI	10..28V	SI	275x225x120mm
RPWM003-12	5000 W	12VDC 2,3,4 FILI	12V	ESTERNA	290x240x120mm
RPWM003-24	9000 W	24VDC 2,3,4 FILI	24V	ESTERNA	290x240x120mm

# Interruttori per pompa di sentina

ACCESSORIES

## BILGE PUMP SWITCHES

Tramite due sensori in acciaio INOX, l'interruttore BILAC001 rileva la presenza di acqua in sentina e comanda la pompa collegata per il perfetto drenaggio del vano in modo automatico. Se collegato al pannello BILAC002 offre inoltre la funzione di allarme sonoro e visivo immediatamente visualizzabile da plancia in caso di malfunzionamento della pompa stessa. Entrambi gli apparecchi si adattano perfettamente ad ogni tipo di pompa di sentina e ad imbarcazioni di qualsiasi dimensione. Adatto per pompe di sentina fino a 20A

*Thanks to two stainless steel sensors, the BILAC001 switch detects the presence of bilge water and automatically activates the relative drain pump. If it is connected to the BILAC002 panel, it also transmits an audio and visual alarm directly to the bridge in the event of a pump malfunction. Both pieces of equipment are perfectly suitable to any kind of bilge pump and to any size of craft. Suitable for bilge pumps up to 20A*



# Interruttori Magneto Idraulici

ACCESSORIES

## MAGNETO-HYDRAULIC BREAKERS



L'interruttore magneto idraulico protegge i motori da sovraccarichi e corto circuito. Specificamente studiato per l'utilizzo in corrente continua, interviene in caso di sovracorrente interrompendo il circuito, in maniera da evitare danni al motore. Disponibile in tre versioni in base alla potenza del motore, alimentabile a 12/24Vdc.

*The magneto-hydraulic breaker protects motor from overcharges and short circuits. It has been studied for D.C. employ and it intervenes in case of over-current breaking the circuit, in order to avoid to damage the motor. It is available in three versions, according to the capacity of the motor, power supply 12/24Vdc.*

	Ampere	Misure
MGN.50_BL	50	L47mm x H75mm x P72mm
MGN.60_BL	60	L47mm x H75mm x P72mm
MGN.70_BL	70	L47mm x H75mm x P72mm
MGN.80_BL	80	L47mm x H75mm x P72mm
MGN.100_BL	100	L47mm x H75mm x P72mm
MGN120BS	120	L47mm x H85mm x P36mm
MGN150BS	150	L47mm x H85mm x P36mm
MGN200BS	200	L47mm x H85mm x P36mm

WBC/S-2.0



Il WBC/S-2.0 consente il controllo di un winch dotato di doppia velocità tramite due pulsanti. Permette di arrestare il winch al raggiungimento di una soglia di corrente impostabile tramite un commutatore. Calibrando il valore della corrente di intervento è possibile avere un controllo ottimale del livello di tiro della fune avvolta.

**PRICIPALI CARATTERISTICHE TECNICHE:**

- Tensione di alimentazione: da 10 a 32VDC
- Comandi: da pulsanti con contatto normalmente aperto.
- Possibilità di impostare la corrente e del ritardo d'intervento.
- Utilizzabile con qualsiasi tipo di motore in corrente continua: 2/3/4 fili.
- Portata massima sensore corrente 250A
- Corrente di intervento impostabile da 75A a 225A con incrementi di 10A
- Protetto contro l'inversione di polarità per errato collegamento della batteria

*The WBC / S-2.0 allows the control of a double speed winch through two buttons. It allows to stop the winch when a current threshold can be set through a switch.*

*By calibrating the value of the tripping current it is possible to have an optimal control of the rolled rope pull level.*

**PRICIPAL TECHNICAL CHARACTERISTICS:**

- Power supply voltage: from 10 to 32VDC
- Control: from buttons with normally open contact.
- Possibility to set the current and the intervention delay.
- Can be used with any type of DC motor: 2/3/4 wires.
- Maximum current sensor range 250A
- Tripping current adjustable from 75A to 225A in increments of 10A
- Protected against polarity inversion due to incorrect connection of the battery

L'apparecchiatura consente il controllo di un winch con uno o due pulsanti con il passaggio automatico dall'alta velocità alla bassa quando viene raggiunto il massimo valore di corrente impostato.

**PRICIPALI CARATTERISTICHE TECNICHE:**

- Tensione di alimentazione; da 10 a 28VDC con impostazione automatica al power on.
- Comandi: da pulsanti con contatto normalmente aperto.
- Impostazione digitale della corrente e del ritardo d'intervento.
- Visualizzazione corrente con display a 3 digit

*This device allows you to have control of a winch with one or two buttons only. It will automatically pass from high to low speed when the maximum set power measure is reached.*

**MAIN TECHNICAL CHARACTERISTICS:**

- Power supply voltage: from 10 to 28 VDC with automatic setting when switched on.
- Control: from buttons with a normally open connection.
- Digital setting for power and operation delay.
- Power view on a 3 digit display.

	Wat	Volt	Misure/Size
WBC/S-2.0	1500 e 2000 W	24	65X56X33
WBC/S-2.0	1500 W	12	65X56X33

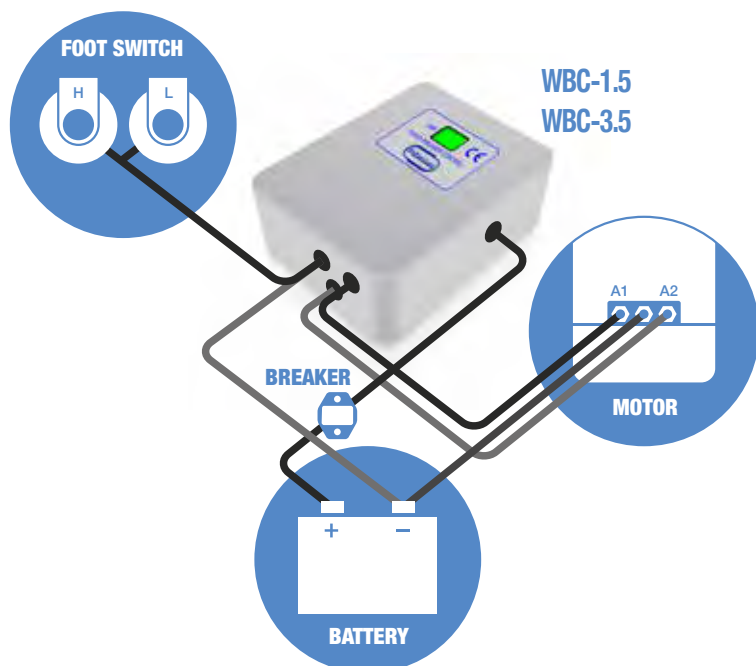

	Wat	Volt	Misure/Size
WBC 1.5	700 e 1500 W	12.24	190x160x80
WBC 3.5	1700 e 3000W	24	240x190x100



**LINEA ENERGIA**  
ENERGY LINE



## BATTERY CHARGERS

I carica batteria serie OCEAN sono studiati per coprire le esigenze di carico più pesanti mantenendo sempre, come peculiarità, elevate prestazioni e la totale sicurezza. La nuova serie OCEAN PLUS si differenzia per la qualità del design dalla scocca completamente in acciaio inox AISI 316

*The battery chargers series OCEAN are studied in order to cover the high load requirements maintaining elevated performances and total security. The New line OCEAN PLUS differs for the quality of the design for its case in Stainless steel AISI 316*

### SERIE OCEAN PLUS



### Caratteristiche per tutti i modelli

- Alimentazione universale con PFC attivo
- Compatibile con batterie al piombo, Gel e AGM
- Compensazione Voltaggio / temperatura
- Controllo di velocità fan
- Alta efficienza e alta affidabilità
- Protezione cortocircuito / sovravoltaggio / sovratemperatura / Brown-out batterie
- Resistenza 2G al test di vibrazione

### Features on all models

- *Universal AC input with active PFC*
- *Compatible with Lead Acid, Li-ion, Gel and AGM batteries*
- *Voltage / temperature compensation*
- *Fan speed control*
- *High efficiency and high reliability*
- *Protection Short Circuit / Over Voltage / Over Temperature / Brown-out Protection*
- *Withstand 2G vibration test*

### Caratteristiche solo serie Ocean

- Compatibile con batterie al piombo, Li-ion, Gel e AGM
- Il pannello di controllo remoto MZBC\_RP è opzionale.
- Controllo di velocità fan a 2 step (modalità sleep)
- Segnale di OK di potenza di uscita
- Segnale di allarme uscita
- Funzione integrata di soccorso batteria
- Funzione integrata ESB Engine Start Battery (ESB)

### Features only on Oceans serie

- *Compatible with Lead Acid, Li-ion, Gel and AGM batteries*
- *Support remote controller MZBC\_RP as optional accessory.*
- *2 stage fan speed control (Sleep mode)*
- *Output power OK signal*
- *Output alarm signal*
- *Built-in battery rescue function*
- *Built-in Engine Start Battery (ESB) output function*

	SERIE OCEAN PLUS		SERIE OCEAN		
	MZ_OP_1218	MZ_OP_1225	MZBC_1250	MZBC_1280	MZBC_2440
Tipo di batteria <i>Battery Type</i>	Piombo/Gel/AGM <i>Lead Acid/Gel/AGM</i>		piombo / Li-ion / Gel / AGM <i>Lead Acid / Li-ion / Gel / AGM</i>		
Tensione di boost standard <i>Standard Boost Charge Voltage</i>	14.5V / 14.8V		14.4 V / 14.7V		28.8 V / 29.4 V
Tensione float standard <i>Standard Float Charge Voltage</i>	13.3V / 13.5V		13.8V / 13.5V		27.6 V / 27 V
Uscita principale <i>Main Output</i>	3				
Corrente massima su singola uscita <i>Single Output Current Limit</i>	18A	25A	50A	80A	40A
Portata <i>Voltage Range</i>	190~260VAC		90~264VAC		
Frequenza <i>Frequency Range</i>	47~63 Hz				
Dimensioni (Unità: mm) <i>Dimension (WxHxD) (Unit: mm)</i>	240x80x130		213x76x272	213x76x312	213x76x272
Peso (Unità: kg) <i>Packing (Unit: kg)</i>	1.6Kg		3.1	4.0	2.9

Pannello Remoto - Remote panel  
**MZBC\_RP (optional)**



**SERIE OCEAN**



	BULK (CC)	ASSORBIMENTO ABSORPTION (CV)	FLOAT	RICONDIZIONAMENTO FLOAT RECONDITION	BULK (CC)	
<p>24,4/28,8 V</p> <p>13,8/27,6 V</p> <p>12,8/25,6 V</p> <p>Corrente/Current</p> <p>Voltaggio/Voltage</p>						
<p><b>Fase di carica</b> <i>Charging stage</i></p>	<p>Riduce il tempo di carica erogando la massima corrente (modalità a corrente costante)</p> <p>Reduce charging time by charging at maximum current (Constant current mode)</p>	<p>Questa fase assicura che la batteria sia completamente caricata evitando la sovra-carica (modalità a corrente costante)</p> <p>Make sure the nattery is fully charged without overcharging (Constant current mode)</p>	<p>Mantiene la batteria al 100% di carica</p> <p>Maintain the battery at 100% charge condition</p>	<p>Ricondizionamento della batteria</p> <p>Reconditioning the battery</p>	<p>Mantiene la batteria al 100% di carica</p> <p>Maintain the battery at 100% charge condition</p>	<p>Quando la tensione di batteria è inferiore a 12,8/25,6 V per 30 secondi il caricabatteria passa dalla fase FLOAT alla fase BULK</p>
<p><b>Specifiche di carica</b> <i>Charging spec</i></p>	<p>Carica alla corrente massima</p> <p>Charging at rated current</p>	<p>14,4V 28,8V fino a quando la corrente diminuisce al 6,25% della corrente nominale</p> <p>14,4 V 28,8 V until the current drops to 6,25% of rated current</p>	<p>Viene erogata una tensione costante pari a 13,8V / 27,6V</p> <p>Stay at 13,8V / 27,6 V</p>	<p>Viene erogata la corrente nominale fino al raggiungimento di 14,4V / 28,8V</p> <p>14,4 V / 28,8 V with rated current</p>	<p>Viene erogata una tensione costante pari a 13,8V / 27,6V</p> <p>Stay at 13,8 V / 27,6 V</p>	<p>Once battery voltage is below 12,8/25,6 V after 30 seconds, CX will turn from FLOAT to BULK</p>

## CHARGE DISTRIBUTORS

I ripartitori di carica MZ permettono una più efficiente ricarica delle batterie dall'alternatore, grazie ad una caduta di tensione molto ridotta. Disponibili in 4 modelli per ogni tipo di esigenza, sono dotati di ottimi dissipatori in lega leggera anodizzata per un'efficace dispersione del calore anche alla massima corrente.

*The MZ charge distributors offer an enhanced efficiency of the battery charge from the alternator thanks to a very low voltage drop. Available in 4 models to satisfy any requirement they are composed by light anodized alloy heat sinks which enable an efficient heat dispersion even at maximum current.*

RP 12150NC



RP 12100NC



	N. Alternators	N. Exit	Max current for exit	Max Alternator Current	Misure/Size
RP 1250NC	1	2	60A	100A	120 x 64 x 70 mm
RP 12100NC	1	2	120A	140A	120 x 64 x 125 mm
RP 12150NC	1	2	180A	200A	120 x 64 x 180 mm
RP 23100NC	2	3	120A	200A	120 x 64 x 180 mm

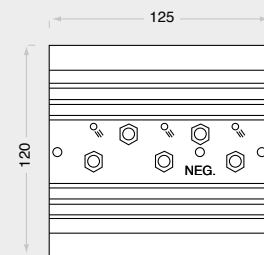
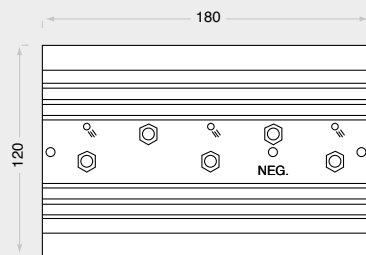



ELICHE DI MANOVRA  
THRUSTERS

*Craftsman*<sup>®</sup>  
MARINE



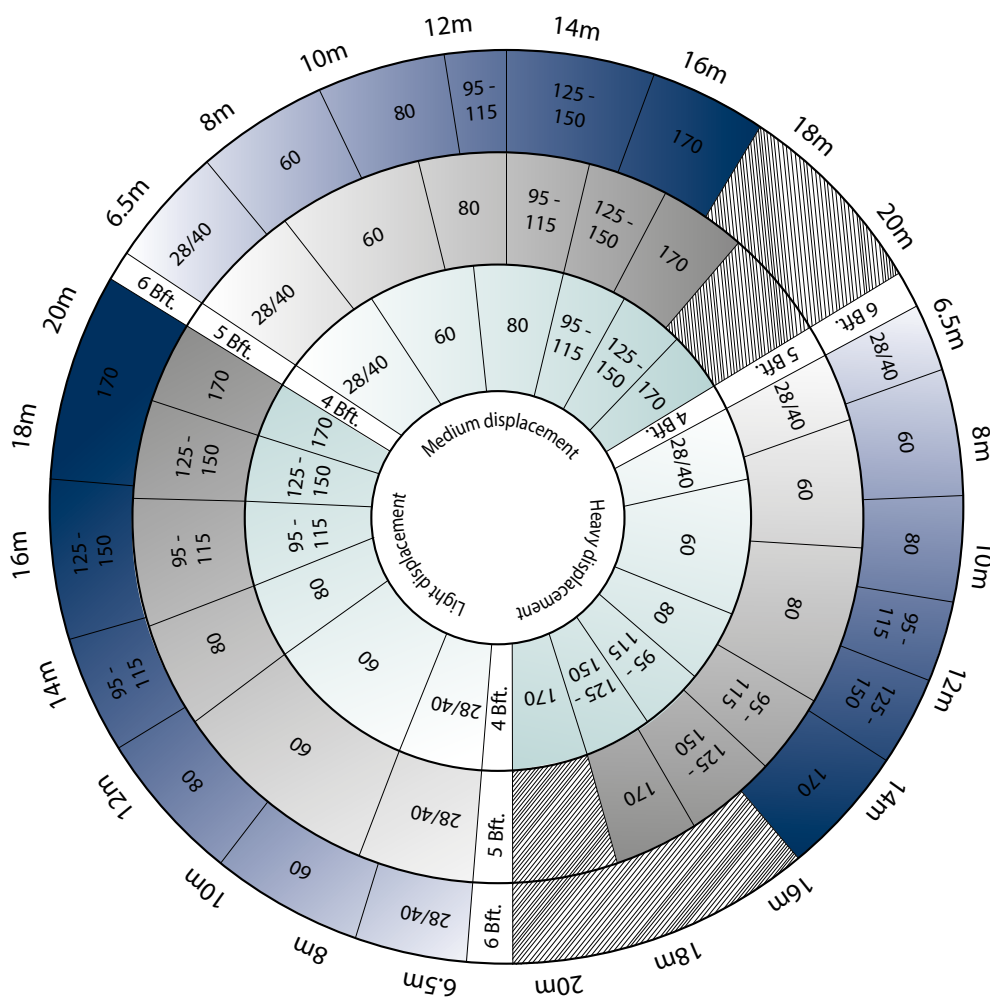
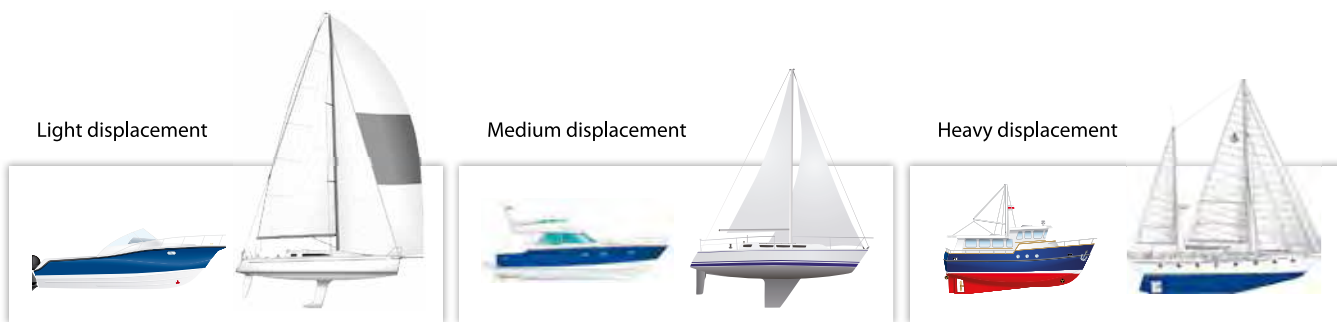

**Passo 1. Selezionare il tipo di imbarcazione. Nel grafico ci sono tre tipi di barca: dislocamento leggero, medio o pesante. Ruotare il grafico in modo che il tipo di barca è rivolta verso l'alto.**

**Passo 2. Selezionare la lunghezza della vostra barca.**

**Passo 3. Scegliere in quali condizioni di vento si desidera essere in grado di manovrare la barca. Si può scegliere tra 4bft (11-16 nodi), 5bft (17-21 nodi) o 6bft (22-27 nodi) – [Bbft = Beaufort]**

**Step 1. Select your type of boat. In the graph are three boat types: light, medium or heavy displacement. Rotate the graph so that your boat type is facing upward.**

**Step 2. Select the length of your boat.**

**Step 3. Choose under what wind conditions you want to be able to manoeuvre the boat. You can choose between 4bft, 5bft or 6bft (bft = beaufort).**

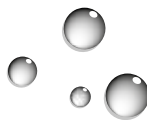

**Questa tabella di selezione è da intendersi come guida. Per maggiori informazioni riguarda alla scelta della corretta elica di monovra vi preghiamo di contattare MZ Electronic.**  
This selection chart is intended as a guide. For more details about thruster selection for your boat please contact MZ Electronic staff.

# THRUSTERS ELETTRICI 28-95Kgf

ELICHE DI MANOVRA

ELECTRIC THRUSTERS 28-95 Kgf



<b>Codice articolo</b> Article code	BA.110.02812	BA.110.04012	BA.150.06012	BA.185.20012	BA.185.20024	BA.185.25012
<b>Spinta (kgf)</b> Thrust force	28	40	60	80	80	95
<b>Diametro del tunnel (mm)</b> tunnel diameter	110	110	150	185	185	185
<b>Potenza motore (kW)</b> Power of electric motor	1.6	2.6	3.7	4	4	5.95
<b>Motore</b> Motor type	12V DC	12V DC	12V DC	12V DC	24V DC	12V DC
<b>Interruttore di temperatura motore</b> Motor temperature switch	YES	YES	YES	YES	YES	YES
<b>Fusibile</b> Fuse	125A	250A	300A	355A	200A	425A

28 kgf 12V 40kgf 12V 60Kgf 12V 80kgf 12V 80kgf 24V 95kgf 12V

<b>A</b>	ø110	ø110	ø150	ø185	ø185	ø185
<b>B</b>	240	276	303	344	307	372
<b>C</b>	ø114	ø118	ø128	ø126	ø128	ø160
<b>D</b>	ø175	ø175	ø175	ø175	ø175	ø200
<b>E</b>	68	68	68	68	68	68
<b>F</b>	238	238	238	238	294	294

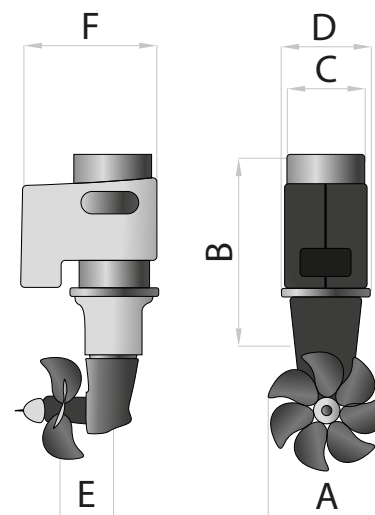

Tutte le misure indicate sono in mm  
All sizes are in mm

# THRUSTERS ELETTRICI 115-170Kgf

ELICHE DI MANOVRA

ELECTRIC THRUSTERS 115-170 Kgf



Codice articolo Article code	BA.185.25024	BA.250.20012	BA.250.20024	BA.250.25024
Spinta (kgf) Thrust force	115	125	150	170
Diametro del tunnel (mm) tunnel diameter	185	250	250	250
Potenza motore (kW) Power of electric motor	5.95	6.5	6.5	11.3
Motore Motor type	24V DC	12V DC	24V DC	24V DC
Interruttore di temperatura motore Motor temperature switch	YES	YES	YES	YES
Fusibile Fuse	250A	500A	250A	355A

	115kgf 24V	125kgf 12V	150kgf 24V	170kgf 24V
A	ø185	ø250	ø250	ø250
B	372	404	404	422
C	ø160	ø160	ø160	ø172
D	ø200	ø200	ø200	ø200
E	68	115	115	115
F	294	294	294	301

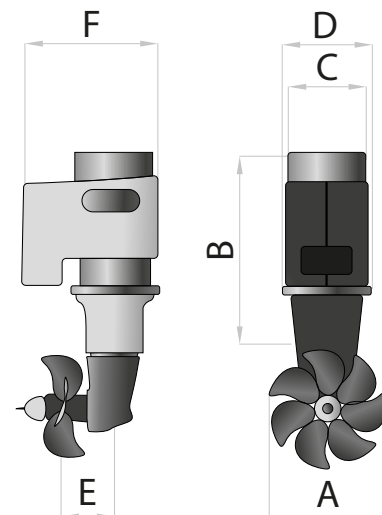

Tutte le misure indicate sono in mm  
All sizes are in mm



# THRUSTERS IDRAULICI

ELICHE DI MANOVRA

HYDRAULIC THRUSTERS



Codice articolo Article code	BA.150.20006	BA.185.20006	BA.185.20008	BA.250.20008	BA.250.20011
Spinta (kgf) Thrust force	50-65	80-115	80.115	120-180	120-180
Diametro del tunnel (mm) tunnel diameter	150	185	185	250	250
Potenza motore (kW) Power of electric motor	3-3.8	4-6	4-6	6.5-12	6.5-12
Motore Motor type	6 cc/rev	6 cc/rev	8 cc/rev	8.4 cc/rev	10.8 cc/rev
Interruttore di temperatura motore Motor temperature switch	YES	YES	YES	YES	YES

	BA.150.20006	BA.185.20006	BA.185.20008	BA.250.20008	BA.250.20011
<b>A</b>	119	124,5	124,5	181	181
<b>B</b>	68	68	68	115	115
<b>C</b>	ø175	ø175	ø175	ø200	ø200
<b>D</b>	259	227	277	344,5	344,5
<b>E</b>	ø150	ø185	ø185	ø250	ø250

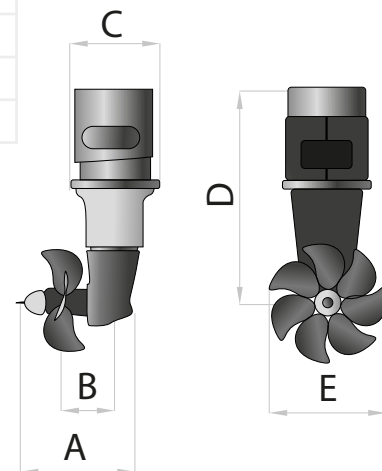

Tutte le misure indicate sono in mm  
All sizes are in mm

## BOW-STERN TUNNELS

Craftsman Marine fornisce i tunnel richiesti in diverse lunghezze e diametri. Il diametro del tunnel dipende dal propulsore scelto. I tunnel sono realizzati in fibra di vetro rinforzata ed i nuovi tunnel di poppa sono costruiti a sandwich.

Le fibre di vetro sono rinforzate con poliestere riempito con schiuma. Grazie a questa scelta non solo hanno un bell'aspetto ma aiutano a ridurre il rumore. Il grande raggio alle estremità del tunnel riduce la turbolenza alle grandi velocità. I tunnel di poppa sono disponibili per eliche da 150 mm e 185 mm.

Le imbarcazioni con poco pescaggio possono utilizzare il tunnel di poppa ma hanno bisogno di un kit deflettore aggiuntivo. Queste coperture sono montate sul tunnel e riducono al minimo la quantità di aria aspirata. Il flusso d'acqua fuori dal tunnel è leggermente deviato verso il basso per avere il massimo effetto.

*Craftsman Marine can supply the required tunnels in various lengths and diameters. The diameter of the tunnel depends on the chosen thruster. Tubes are made from GRV (glassfiber reinforced vinylester). The new stern thruster tunnels are build in sandwich construction.*

*Glassfiber reinforced polylester filled with PU foam. Because of this construction they not only have great looks but also help reduce noise. The large radius at the ends of the tunnel reduce turbulence for maximum performance. Stern thruster tunnels are available for 150mm and 185mm thrusters.*

*Shallow draft vessels can still use the stern tunnel but need an additional deflector kit. These additional covers are mounted on the tunnel and minimize the amount of false air being sucked into the tunnel. The waterflow out of the tunnel is slightly deflected downwards to have maximum effect*



<b>BG.110.21100</b>	Tunnel in vetroresina / GRV tunnel D 110mm L 1000mm
<b>BG.150.21100</b>	Tunnel in vetroresina / GRV tunnel D 150mm L 1000mm
<b>BG.185.21100</b>	Tunnel in vetroresina / GRV tunnel D 185mm L 1000mm
<b>BG.250.21100</b>	Tunnel in vetroresina / GRV tunnel D 250mm L 1000mm
<b>BG.250.21150</b>	Tunnel in vetroresina / GRV tunnel D 250mm L 1500mm



<b>BB.010.25110</b>	Tunnel di Poppa D 110mm / Stern thruster tunnel 110mm
<b>BB.010.25150</b>	Tunnel di Poppa D 150mm / Stern thruster tunnel 150mm
<b>BB.010.25185</b>	Tunnel di Poppa D 185mm / Stern thruster tunnel 185mm
<b>BB.010.25250</b>	Tunnel di Poppa D 250mm / Stern thruster tunnel 250mm



<b>BB.010.20150</b>	Tunnel di Poppa D 150mm / Stern thruster tunnel 150mm
<b>BB.050.20150</b>	Deflettori per tunnel D 150mm / Deflection covers 150mm
<b>BB.010.20185</b>	Tunnel di Poppa D 185mm / Stern thruster tunnel 185mm
<b>BB.050.20185</b>	Deflettori per tunnel D 150mm / Deflection covers 185mm

## CONTROL PANELS

Le eliche di prua e di poppa liberano lo skipper dal suo faticoso lavoro manuale. I pannelli di comando della Craftsman Marine e le eliche di prua e di poppa contribuiscono a rendere più semplice l'operazione di ormeggio. Basta una sola pressione sul pulsante o sul joystick per gestire una serie di movimenti complessi in modo molto più semplice.

Nel caso della sola elica di prua, viene utilizzato un unico pannello. Il doppio pannello serve per gestire sia l'elica di prua che quella di poppa. In tal caso, ogni elica viene manovrata con il proprio joystick. Le estremità dei pannelli sono realizzati a tenuta stagna in conformità con la protezione IP 66.

I pannelli di controllo Craftsman Marine sono realizzati da un foglio di alluminio e successivamente anodizzati per garantire una perfetta protezione contro tutte le condizioni meteorologiche.

*Bow and stern thrusters liberate the skipper from his heavy handiwork. The control panels of the Craftsman Marine bow and stern thrusters also contribute to optimum ease of operation. It is just a push on the button, or to the joystick that triggers a range of complex movements in the most simple way.*

*In the case of only a bow thruster, a single panel is used. Dual panels serve the purpose of both a bow and a stern thruster. In that case, each thruster has its own joystick. The top sides of the panels are made watertight in accordance with the protection classification IP 66.*

*Craftsman Marine thruster control panels are milled from an aluminium sheet and thereafter anodized to ensure perfect protection against all (marine) weather conditions.*



CODICE ARTICOLO	BC.010.20001	BC.010.20002	BC.010.20003	BC.010.20001	BC.010.20002	BC.010.20003
DIMENSIONI	81 x 85 mm	81 x 85 mm	81 x 136 mm	81 x 85 mm	81 x 85 mm	81 x 136 mm
PROTEZIONE PER INVERSIONE DI MARCIA DEL MOTORE	Ritardo programmato di un secondo sul cambio di direzione di spinta. Questa funzione può essere disabilitata.			Programmed delay of a second on the change of direction of thrust. This function can be uninhabited.		
INTERRUTTORE DI PROTEZIONE TEMPERATURE	Tutti motori elettrici sono forniti con un interruttore di protezione termico. Il motore è automaticamente spento in caso di temperatura elevata.			All electric motors are supplied with a switch thermal protection. The engine is automatically switched off case of high temperature.		
PANNELLO DI CONTROLLO PER LO SPEGNIMENTO	Questa funzione è attivabile dall'utente. Il pannello può essere spento automaticamente dopo 30 minuti, 60 minuti, o 120 minuti. Impostazione base spegnimento automatico disabilitato.			This function is activated by the user. The panel can be turned off automatically after 30 minutes, 60 minutes, or 120 minutes. Basic setting automatic shut-off disabled.		
PANNELLO DI ACCENSIONE	Protezione integrata per prevenire che il pannello sia acceso accidentalmente			Built-in protection to prevent the panel is turned on accidentally		
PROTEZIONE CONTO USO CONTINUATIVO	Questa funzione attivabile dall'utente. Dopo due minuti. Di uso continuativo viene spento automaticamente. Se questa funzione disabilitata scatta l'allarme visivo sonoro nel caso il motore sia usato per più di due minuti il motore non si spegne			This function is activated by the user. After two minutes. of continued use is automatically turned off. If this function uninhabited visual sound the alarm if the motor is used for more than two minutes, the engine stops		
CLASSE DI PROTEZIONE	IP66 (parte frontale del pannello)			IP66 (front panel)		

## EXTENSION CABLES FOR THRUSTERS

I cavi di estensione Craftsman sono disponibili in lunghezze di 7m, 10m, 15m e 20m. È possibile collegare diverse lunghezze di cavo insieme. Per proteggere l'impianto elettrico da umidità, sale, acqua e polvere, tutti i nostri cavi sono provvisti di connettori resistenti all'acqua.

*The Craftsman Marine extension cables are available in lengths of 7m, 10m, 15m and 20m. It is possible to connect different cable lengths together. To protect the electrical installation against moisture, salt, water, dust or dirt, all our cables are fitted with waterproof connectors.*



- Connettori impermeabili Guarnizioni in gomma IP67
- Chiusura a leva a scatto, per garantire una connessione al 100%, anche in caso di vibrazioni.
- Con il cavo splitter è molto facile realizzare i collegamenti per i pannelli fly-bridge

- *Waterproof connectors IP67 rubber sealing*
- *Latch lever lock, to ensure a 100% tight connection, also in case of vibrations.*
- *With the splitter cable it is very easy to make the connections for fly-bridge panels*

**BC.010.25030**

**BC.010.25020**



### Pannelli di comando eliche idrauliche

Quando stai cercando un joystick per controllare la tua elica di manovra, un proiettore o qualsiasi altra applicazione che richiede solo un semplice interruttore, il joystick Craftsman Marine è il controllo che fa per te. Abbina l'aspetto e la qualità del microprocessore controllato dal pannello.

### Hydraulic Thruster panels

*When you are looking for a switch-joystick to control your hydraulic propulsion flybridge panels thruster, searchlight or any other application that requires just a simple switch, the Craftsman Marine joystick is the control for you. It matches the looks and feel of the microprocessor controlled thruster panels.*



**ELICHE DI MANOVRA**  
THRUSTERS



# ELICHE DI MANOVRA

## THRUSTERS

Le eliche di manovra ITALWINCH nascono da un'attenta e accurata progettazione e grazie al know-how oltre ventennale che vanta l'azienda. Ideate e fabbricate completamente in Italia, godono di un elevato standard qualitativo; inoltre è stata posta un'attenzione peculiare per i dettagli e per la scelta dei componenti, segni distintivi che fanno del marchio ITALWINCH una garanzia. Le eliche di manovra Italwinch si contraddistinguono, infatti, per il motore in alluminio, il corpo in acciaio e le eliche in Nibral.

Le eliche, esclusivamente a 4 pale, sono il migliore risultato tra efficienza, silenziosità e risparmio energetico. Con due eliche controrotanti permette di affrontare le manovre di ormeggio con la massima efficacia. I motori in alluminio sono stati progettati per garantire elevate prestazioni in qualsiasi condizione, assicurando nel frattempo una lunga durata, grazie anche al sistema di verifica costante del surriscaldamento del motore stesso.

La gamma è stata sviluppata specificatamente per superyacht e megayacht, con prestazioni di spinta fino a 1500 Kgf. Sono previste motorizzazioni elettriche ed idrauliche; disponibili sia nella versione di poppa che di prua, grazie agli appositi sistemi di fissaggio e alla scelta dei relativi tunnel nella versione in vetroresina ed in acciaio. È stata posta molta attenzione anche alla scelta dei comandi remoti, così da poter gestire sempre nel modo più efficiente le manovre in porto.

*ITALWINCH thrusters are born from a careful and accurate design and thanks to the over twenty years know-how which the company boasts. Completely designed and manufactured in Italy, they enjoy a high quality standard; moreover, particular attention was paid to the details and to the choice of components, distinctive signs that make the ITALWINCH brand a guarantee.*

*Indeed, the Italwinch thrusters are characterized by the aluminum engine, the steel body and the Nibral propellers. The propellers, exclusively with 4 blades, are the best result of efficiency, silence and energy saving. With two counter-rotating propellers allows to handle mooring manoeuvres in maximum effectiveness. The aluminum engines have been designed to guarantee high performance in all conditions, ensuring a long life in the meantime. The range has been developed specifically for superyachts and megayachts, with thrust performance up to 1500 kgf.*

*Electric and hydraulic motors are provided; available both in stern and in bow versions, thanks to the special fastening systems and to the choice of the related tunnel in the fiberglass version and in steel. Attention was also paid to the choice of remote controls in order to always manage the maneuvers in the port in the most efficient way.*

- **Motore in alluminio**
  - **Corpo in acciaio inox**
  - **Eliche in Nibral a 4 pale**
  - **2 eliche controrotanti**
- *Aluminum engine*
  - *Stainless steel body*
  - *Propellers in Nibral with 4 blades*
  - *2 counter-rotating propellers*

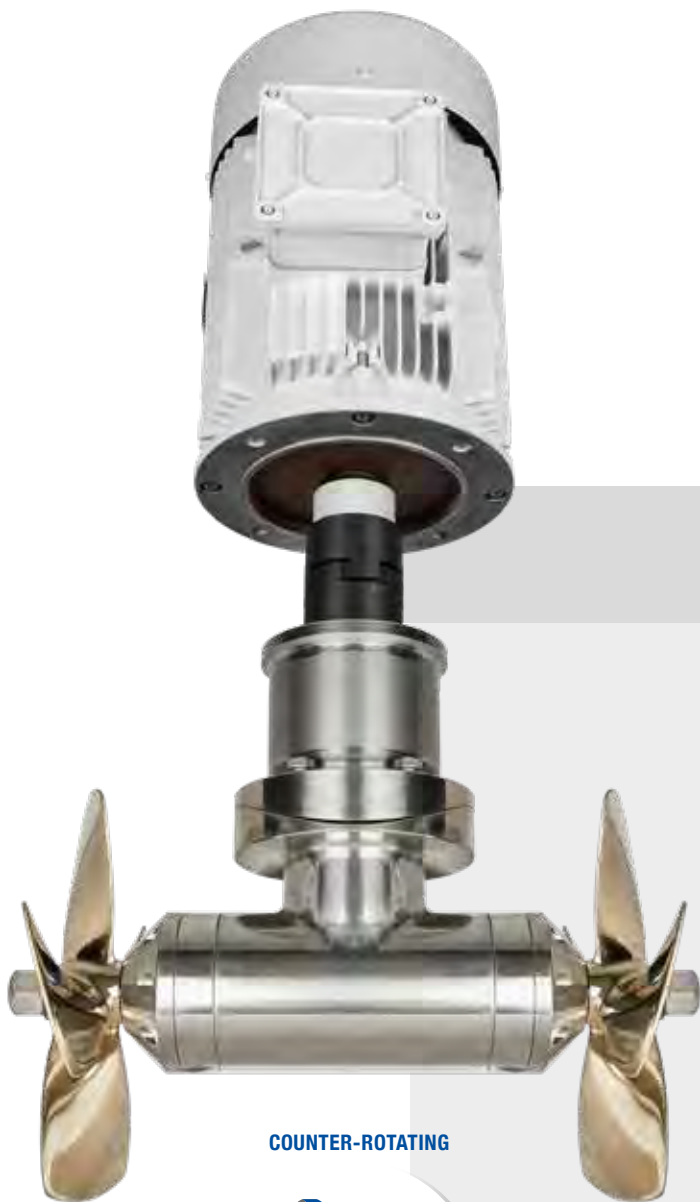

**COUNTER-ROTATING**

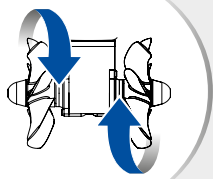

CODICE CODE	DIAMETRO TUNNEL TUNNEL DIAMETER	ELICHE PROPELLERS	MOTORE MOTOR	POTENZA POWER	SPINTA THRUST
IWT_AC015_350	350mm	2	Ac 3ph	15 Kw	300 Kgf
IWT_AC015_350_H	350mm	2	Ac 3ph	15 Kw	300 Kgf
IWT_AC022_350	350mm	2	Ac 3ph	22 Kw	450 Kgf
IWT_AC022_350_H	350mm	2	Ac 3ph	22 Kw	450 Kgf
IWT_AC030_350	350mm	2	Ac 3ph	30 Kw	500 Kgf
IWT_AC030_350_H	350mm	2	Ac 3ph	30 Kw	500 Kgf
IWT_AC030_400	400mm	2	Ac 3ph	30 Kw	550 Kgf
IWT_AC037_400	400mm	2	Ac 3ph	37 Kw	600 Kgf
IWT_AC037_450	450mm	2	Ac 3ph	37 Kw	630 Kgf
IWT_AC045_450	450mm	2	Ac 3ph	45 Kw	720 Kgf
IWT_AC055_500	500mm	2	Ac 3ph	55 Kw	960 Kgf
IWT_AC075_500	500mm	2	Ac 3ph	75 Kw	1100 Kgf
IWT_AC055_550	550mm	2	Ac 3ph	55 Kw	1200 Kgf
IWT_AC075_550	550mm	2	Ac 3ph	75 Kw	1300 Kgf



- **Corpo in acciaio inox**
- **Eliche in Nibral a 4 pale**
- **2 eliche controrotanti**
- *Stainless steel body*
- *Propellers in Nibral with 4 blades*
- *2 counter-rotating propellers*

COUNTER-ROTATING

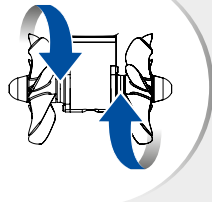

CODICE CODE	DIAMETRO TUNNEL TUNNEL DIAMETER	ELICHE PROPELLERS	MOTORE MOTOR	POTENZA POWER	SPINTA THRUST
IWT_HY022_350	350mm	2	HYD	22 Kw	450 Kgf
IWT_HY030_350	350mm	2	HYD	30 Kw	500 Kgf
IWT_HY030_400	400mm	2	HYD	30 Kw	550 Kgf
IWT_HY037_400	400mm	2	HYD	37 Kw	600 Kgf
IWT_HY037_450	450mm	2	HYD	37 Kw	630 Kgf
IWT_HY045_450	450mm	2	HYD	45 Kw	720 Kgf
IWT_HY055_500	500mm	2	HYD	55 Kw	960 Kgf
IWT_HY075_500	500mm	2	HYD	75 Kw	1100 Kgf
IWT_HY055_550	550mm	2	HYD	55 Kw	1200 Kgf
IWT_HY075_550	550mm	2	HYD	75 Kw	1300 Kgf



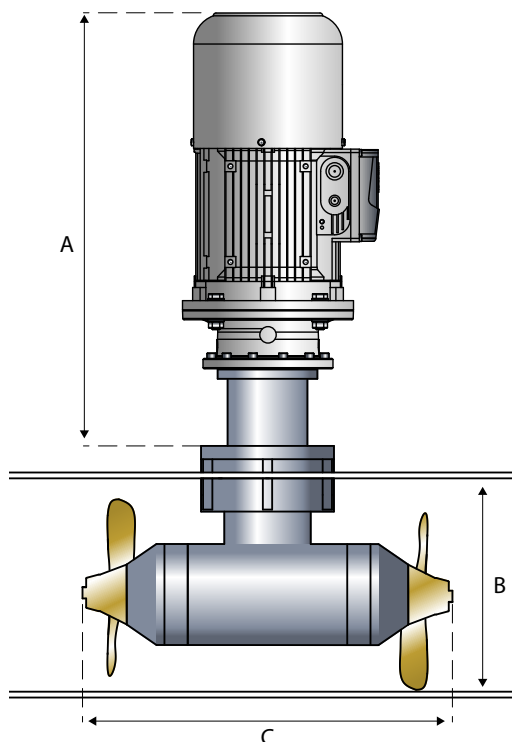
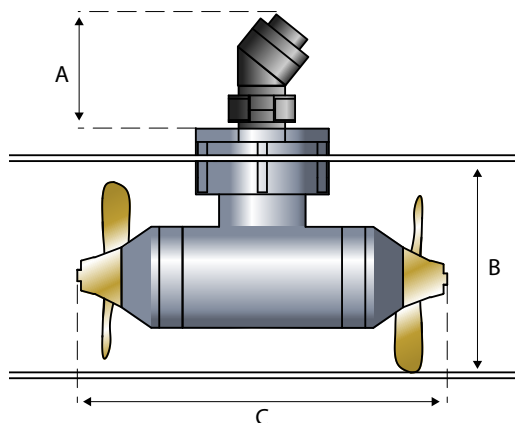

## IDRAULICO/HYDRAULIC

CODICE CODE	POTENZA MOTORE POWER ENGINE	A (mm)	B (mm)	C (mm)
IWT_HY022_350	22 Kw	450	350	600
IWT_HY030_350	30 Kw	450	350	600
IWT_HY030_400	30 Kw	500	400	745
IWT_HY037_400	37 Kw	500	400	745
IWT_HY037_450	37 Kw	500	450	745
IWT_HY045_450	45 Kw	500	450	745
IWT_HY055_500	55 Kw	530	500	920
IWT_HY075_500	75 Kw	530	500	920
IWT_HY055_550	55 Kw	530	550	920
IWT_HY075_550	75 Kw	530	550	920

## ELETTRICO/ELECTRIC

CODICE CODE	POTENZA MOTORE POWER ENGINE	A (mm)	B (mm)	C (mm)
IWT_AC015_350	15 Kw	700	350	600
IWT_AC015_350_H	15 Kw	910	350	600
IWT_AC022_350	22 Kw	740	350	600
IWT_AC022_350_H	22 Kw	950	350	600
IWT_AC030_350	30 Kw	790	350	600
IWT_AC030_350_H	30 Kw	1000	350	600
IWT_AC030_400	30 Kw	790	400	745
IWT_AC037_400	37 Kw	900	400	745
IWT_AC037_450	37 Kw	900	450	745
IWT_AC045_450	45 Kw	900	450	745
IWT_AC055_500	55 Kw	1010	500	920
IWT_AC075_500	75 Kw	1120	500	920
IWT_AC055_550	55 Kw	1010	550	920
IWT_AC075_550	75 Kw	1120	550	920

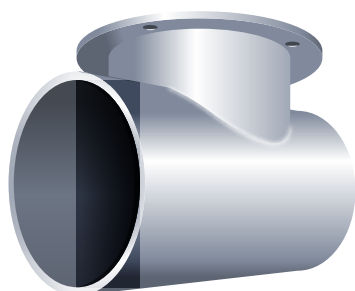
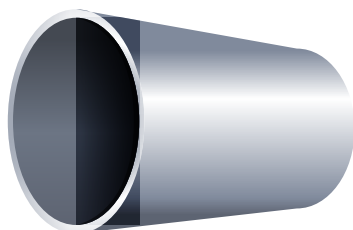

	Spessore / Thickness	Acciaio / Steel	Vetroresina / Fiberglass
CARATTERISTICHE	Tunnel di prua / Bow Tunnel 350mm	10 mm	18 mm
	Tunnel di prua / Bow Tunnel 400mm	10 mm	20 mm
	Tunnel di prua / Bow Tunnel 450mm	10 mm	20 mm
	Tunnel di prua / Bow Tunnel 500mm	12,5 mm	25 mm
	Tunnel di prua / Bow Tunnel 550mm	12,5 mm	25 mm

	Spessore / Thickness	Acciaio / Steel	Vetroresina / Fiberglass
CARATTERISTICHE	Tunnel di prua / Bow Tunnel 350mm	10 mm	18 mm
	Tunnel di prua / Bow Tunnel 400mm	10 mm	20 mm
	Tunnel di prua / Bow Tunnel 450mm	10 mm	20 mm
	Tunnel di prua / Bow Tunnel 500mm	12,5 mm	25 mm
	Tunnel di prua / Bow Tunnel 550mm	12,5 mm	25 mm



L'intera gamma di thruster elettrici Italwinch è supportata da inverter progettati per variare la velocità del motore del thruster garantendone la massima efficienza ed affidabilità.

Studiato per alimentare i dispositivi elettronici che funzionano in corrente alternata, l'inverter è un variatore che gestisce l'efficienza e la costanza dei processi.

Per il funzionamento dei comandi proporzionali ed eliche di manovra equipaggiati con motori AC, Italwinch ha sviluppato inverter di ultima generazione, in grado di ottimizzare il risparmio energetico tramite la regolazione automatica di frequenze e tensioni.

*The entire range of Italwinch electric thrusters is supported by inverters designed to vary the thruster engine speed ensuring maximum efficiency and reliability.*

*Designed to power electronic devices that operate in alternating current, the inverter is a variable speed drive that manages efficiency and consistency of processes.*

*For the operation of the proportional controls and thrusters equipped with AC motors, Italwinch has developed the latest generation of inverters, able to optimize energy savings through the automatic regulation of frequencies and voltages*



- Comandi per thrusters con sistema proporzionale
  - Facilità di installazione
  - Comando proporzionale destra/sinistra
  - Grafica intuitiva
  - Possibilità di connettere più postazioni di comando in parallelo
- *Thrusters controls with proportional system*
  - *Easy to install*
  - *Proportional right/left control*
  - *Intuitive graphics*
  - *Possibility to connect several command stations in parallel*

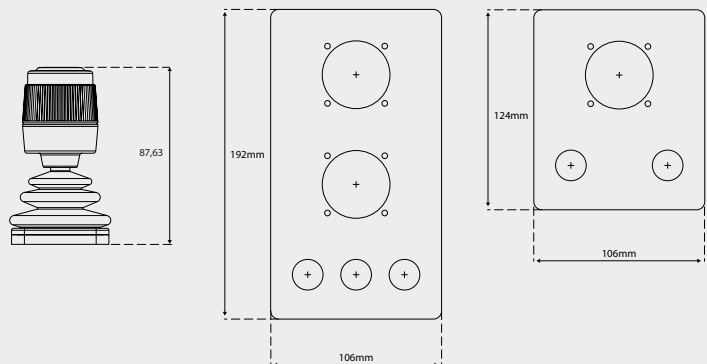

**Il sistema di controllo thruster consente di comandare i propulsori di prua e di poppa.**

*The thruster control system allows you to control the bow and stern thruster.*

- Possibilità di comandare fino a due motori (prua + poppa). Ciascun motore può essere comandato da un numero massimo di 4 postazioni
  - Comando con joystick proporzionale
  - Sistema di priorità a chiamata tra le varie postazioni
  - Segnalazioni di allarme inverter tramite avvisatore acustico e led di allarme
  - Disabilitazione automatica della postazione joystick per inattività prolungata
  - Protezione contro l'inversione di polarità dell'alimentazione
  - Facilità di installazione
- *Possibility to control up to two motors (bow + stern). Each motor can be controlled by up to 4 stations*
  - *Control with proportional joystick*
  - *Priority call system between the various stations*
  - *Inverter alarm signals via acoustic alarm and LED alarm*
  - *Automatic disabling of the joystick station for prolonged inactivity*
  - *Protection against power supply polarity reversal*
  - *Easy installation*

## HYDRAULIC SYSTEMS

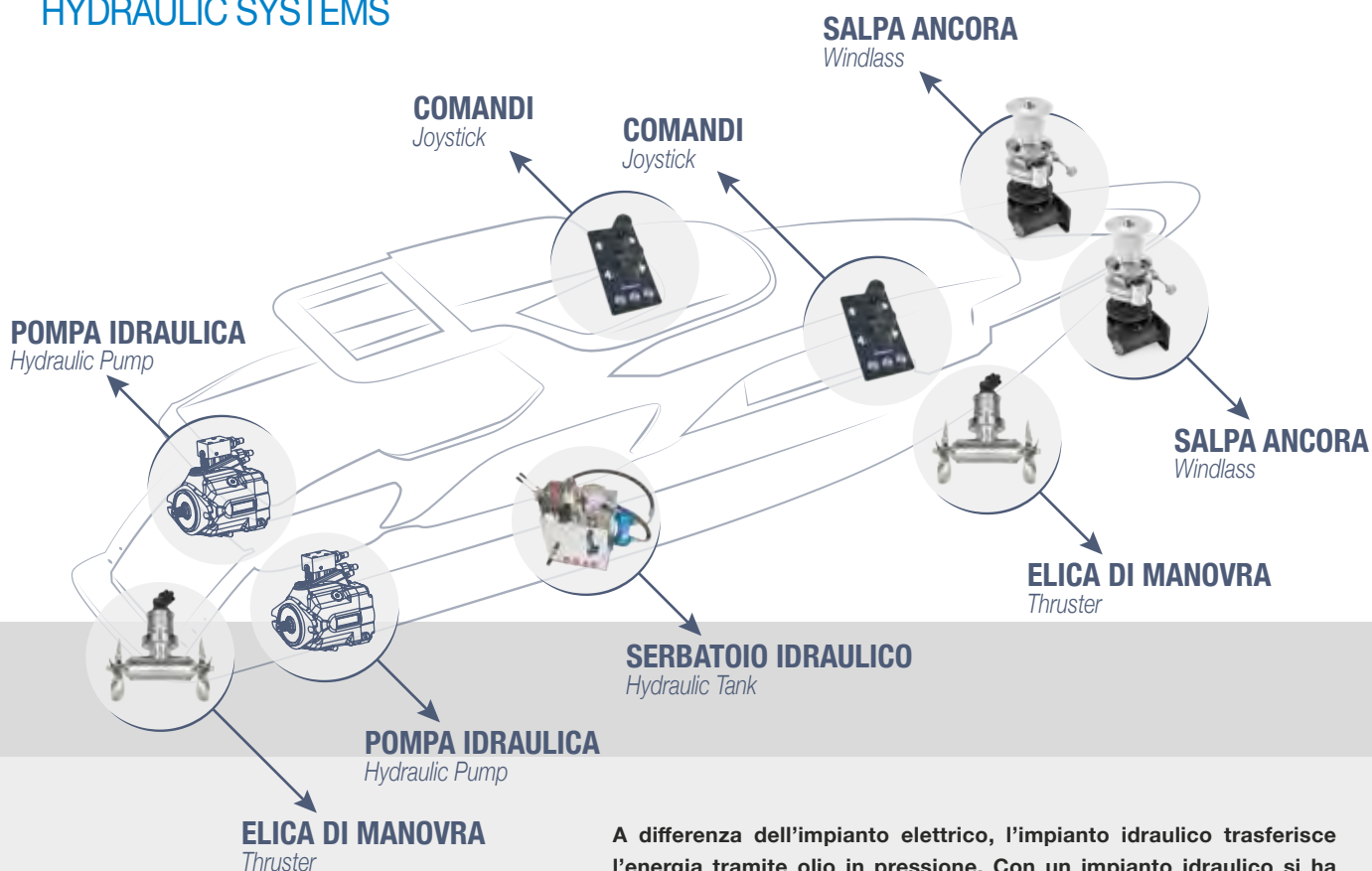

A differenza dell'impianto elettrico, l'impianto idraulico trasferisce l'energia tramite olio in pressione. Con un impianto idraulico si ha il vantaggio di gestire tutte le operazioni tramite un unico gruppo di controllo molto flessibile in quanto offre la possibilità di governare diversi gruppi di utilizzatori, quali appunto eliche di manovra e verricelli.

L'impianto oleodinamico offre inoltre la possibilità di avere la proporzionalità nei comandi, permette di sfruttare gli utilizzatori in tutta sicurezza senza limite di tempo e di riservare meno manutenzione.

L'impianto idraulico è alimentato da un gruppo generatore costituito da un serbatoio e dalla relativa pompa. Il tutto è gestito da un gruppo di controllo costituito da valvole che gestiscono la giusta pressione per ogni gruppo utilizzatore (da 1 a 4).

*Unlike the electrical system, the hydraulic system transfers energy using pressurized oil. With a hydraulic system, there is the advantage of managing all the operations by means of a single, very flexible control group, since it gives the possibility to control different groups of users, such as manoeuvring propellers and winches.*

*The hydraulic system also offers the possibility to have proportionality in the controls, it allows users to exploit safely without time limit and to make less maintenance.*

*The hydraulic system is powered by a generator group consisting of a tank and the relevant pump. Everything is managed by a control group consisting in valves that manage the right pressure for each user group (from 1 to 4).*





progettoelica



# Progettazione e produzione di eliche, timoni e linee d'asse

*Design and production of propellers, rudders and shaft lines*

Progetto Elica nasce dall'esperienza di SBM, storica azienda di eliche italiana nata nel 1963. Siamo specializzati nel calcolo, nella progettazione e produzione di eliche personalizzate, sia immerse che di superficie, linee d'asse e timoni, per imbarcazioni fino a 150 piedi (sia da diporto che da lavoro). Ci avvaliamo di personale con lunga esperienza e riconosciuta professionalità nel settore della propulsione marina, grazie al quale siamo in grado di fornire ai nostri clienti sia eliche personalizzate sulla base delle specifiche della singola imbarcazione, sia repliche di eliche già esistenti.

Le nostre eliche sono il risultato della combinazione di tecnologie avanzate (progettazione con sistemi CAD-CAE-CAM, passometro computerizzato, equilibratura dinamica) e di grande esperienza e abilità manuale nella finitura dei prodotti. Il nostro processo di produzione è controllato ad ogni passaggio, ai fini di fornire prodotti di alta qualità, con prestazioni ottimali in relazione alle caratteristiche della singola imbarcazione.

*Progetto Elica was born from the experience of SBM, a historic Italian propeller company founded in 1963. We are an Italian Company, located near Milan, that specializes in the design and production of custom-made propellers (both fully submerged and surface piercing), shaft lines and rudders for boats up to 150 feet in length (both pleasure and commercial). Because of the long experience and very high skill level of our staff, we can design and produce both customized propellers and replicas of already existing propellers.*

*We employ a combination of advanced technologies (CAD/CAE design, CAM machining, computerized pitch gauge, dynamic balancing), skilled craftsmanship and expertise in the finishing processes of our custom-made propellers. Our production process is tightly controlled at every step, in order to supply high quality propellers, delivering optimal performances relative to the specifications of every single boat.*





MODELLO **SA**

ELICHE DI SUPERFICIE / SURFACE PROPELLERS



SA5	5 pale (blades)
EAR	0,95 ÷ 1,05
P/D max	2.00
RAKE max	12°

SA6	6 pale (blades)
EAR	1,00 ÷ 1,30
P/D max	2.00
RAKE max	12°

**Elica di superficie per scafi plananti pesanti**  
(*surface piercing propeller for heavy planing vessels*)

MODELLO **SB**

ELICHE DI SUPERFICIE / SURFACE PROPELLERS



SB4	4 pale (blades)
EAR	0,56 ÷ 0,90
P/D max	2.00
RAKE max	12°

SB5	5 pale (blades)
EAR	0,70 ÷ 0,90
P/D max	2.00
RAKE max	12°

SB6	6 pale (blades)
EAR	0,90 ÷ 1,10
P/D max	2.00
RAKE max	12°

**Elica di superficie con retromarcia per scafi plananti**  
(*surface piercing propeller with backgear for planing vessels*)

MODELLO **SC**

ELICHE DI SUPERFICIE / SURFACE PROPELLERS



SC4	4 pale (blades)
EAR	0,75 ÷ 0,90
P/D max	2.00
RAKE max	18°

SC5	5 pale (blades)
EAR	0,90 ÷ 1,00
P/D max	2.00
RAKE max	18°

SC6	6 pale (blades)
EAR	1,15 ÷ 1,20
P/D max	2.00
RAKE max	18°

**Elica di superficie tipo "chopper" per scafi plananti**  
(*surface piercing propeller "chopper" type for planing vessels*)



SP4	4 pale (blades)
EAR	0,75 ÷ 0,90
P/D max	2,00
RAKE max	18°

SP5	5 pale (blades)
EAR	0,90 ÷ 1,10
P/D max	2,00
RAKE max	18°

**Elica di superficie per scafi plananti.**  
(*surface piercing propeller for planing vessels*)



SV4	4 pale (blades)
EAR	0,56 ÷ 0,90
P/D max	2,00
RAKE max	0 ÷ 18°

SV5	5 pale (blades)
EAR	0,70 ÷ 0,90
P/D max	2,00
RAKE max	0 ÷ 18°

SV6	6 pale (blades)
EAR	0,90 ÷ 1,10
P/D max	2,00
RAKE max	0 ÷ 18°

**Elica di superficie per scafi plananti.**  
(*surface piercing propeller for light planing vessels*)



SX4	4 pale (blades)
EAR	0,75 ÷ 0,90
P/D max	2,00
RAKE max	7 ÷ 18°

SX5	5 pale (blades)
EAR	0,90 ÷ 1,00
P/D max	2,00
RAKE max	7 ÷ 18°

SX6	6 pale (blades)
EAR	1,15 ÷ 1,20
P/D max	2,00
RAKE max	7 ÷ 18°

**Elica di superficie per scafi plananti.**  
(*surface piercing propeller for planing vessels*)

MODELLO **HB**

ELICHE IMMERSE / SUBMERGED PROPELLERS



HB4	4 pale (blades)
EAR	0,85 ÷ 0,90
P/D max	1,80

HB5	5 pale (blades)
EAR	1,05 ÷ 1,10
P/D max	1,80

**Elica immersa per scafi plananti**  
(submerged propeller for planing vessels)

MODELLO **HK**

ELICHE IMMERSE / SUBMERGED PROPELLERS

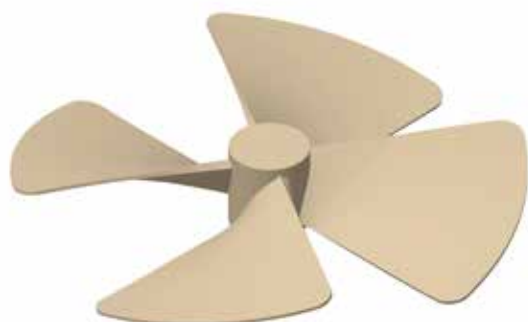

HK3	3 pale (blades)
EAR	0,45 ÷ 0,65

HK4	4 pale (blades)
EAR	0,55 ÷ 0,70

HK5	5 pale (blades)
EAR	0,75 ÷ 0,90

**Elica immersa di manovra e per scafi da lavoro**  
(submerged propeller for thruster and work boat)

MODELLO **HL**

ELICHE IMMERSE / SUBMERGED PROPELLERS



HL3	3 pale (blades)
EAR =	0,65 ÷ 0,75
P/D max =	1,60

HL4	4 pale (blades)
EAR	0,85 ÷ 1,00
P/D max	1,60

**Elica immersa per scafi plananti**  
(submerged propeller for planing vessels)





HM3	3 pale (blades)
EAR	0,65
P/D max	1,80

HM4	4 pale (blades)
EAR	0,95
P/D max	1,80

HM5	5 pale (blades)
EAR	0,95 ÷ 1,10
P/D max	1,80

**Elica immersa per scafi plananti e semiplananti**  
(submerged propeller for planing and semiplaning vessels)



HR4	4 pale (blades)
EAR	0,75 ÷ 0,90
P/D max	1,20

HR5	5 pale (blades)
EAR	0,95 ÷ 1,15
P/D max	1,20

**Elica immersa per scafi plananti e semiplananti**  
(submerged propeller for planing and semiplaning vessels)



HS3	3 pale (blades)
EAR	0,65
P/D max	1,20

HS4	4 pale (blades)
EAR	0,95 ÷ 1,05
P/D max	0,80

HS5	5 pale (blades)
EAR	0,95 ÷ 1,05
P/D max	0,90

**Elica immersa per scafi dislocanti e semiplananti**  
(submerged propeller for displacing and semiplaning vessels)

Timoni su misura per imbarcazioni fino a 50 metri.

Progetto Elica assiste il cliente nella scelta dei timoni più adatti e nella progettazione dello schema della timoneria.

Sono disponibili pale timone in acciaio a lamina, acciaio sciolato o completamente fuse in bronzo; possono essere abbinati a losche in ottone, in alluminio a saldare oppure in vetroresina.

Custom made rudders for boat up to 50 meters

Progetto Elica can assist the customer to choose the right rudders and the steering system design.

Rudder blades made by single steel plate or NACA shaped, totally bronze casted are available; they can be supplied with rudder tubes made by brass, aluminum or VTR

## BRONZE

LD 35.27 D80 L400

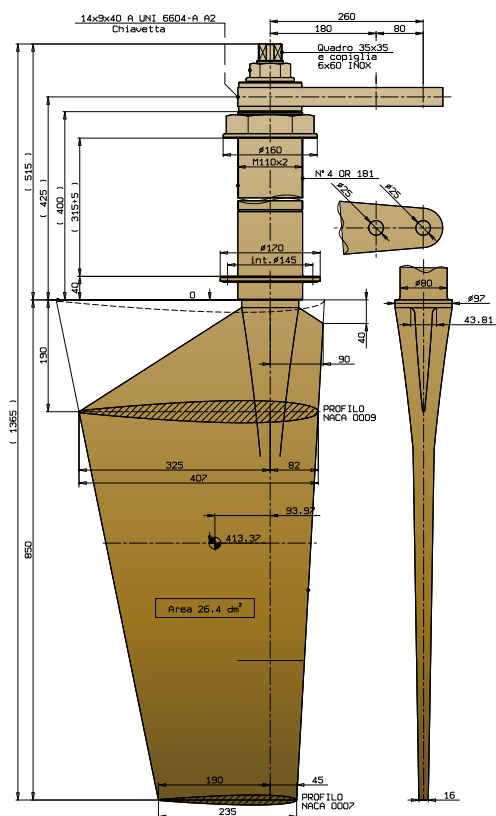

## BRONZE

LD 30.24 D80 L400

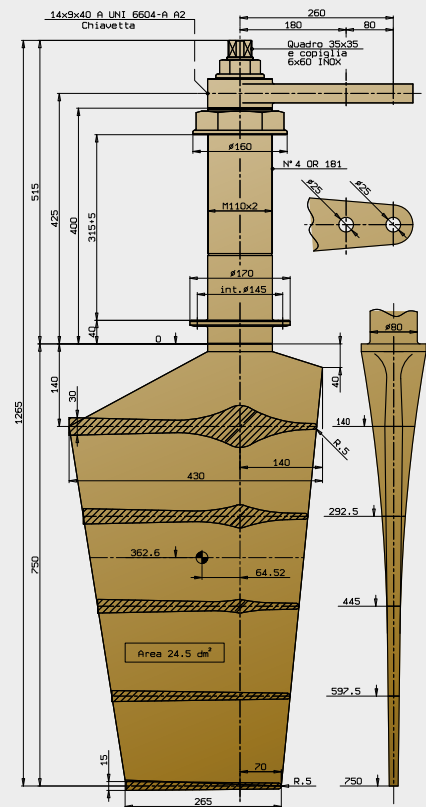

## RUDDERS

### LS 80.25 D60 L620

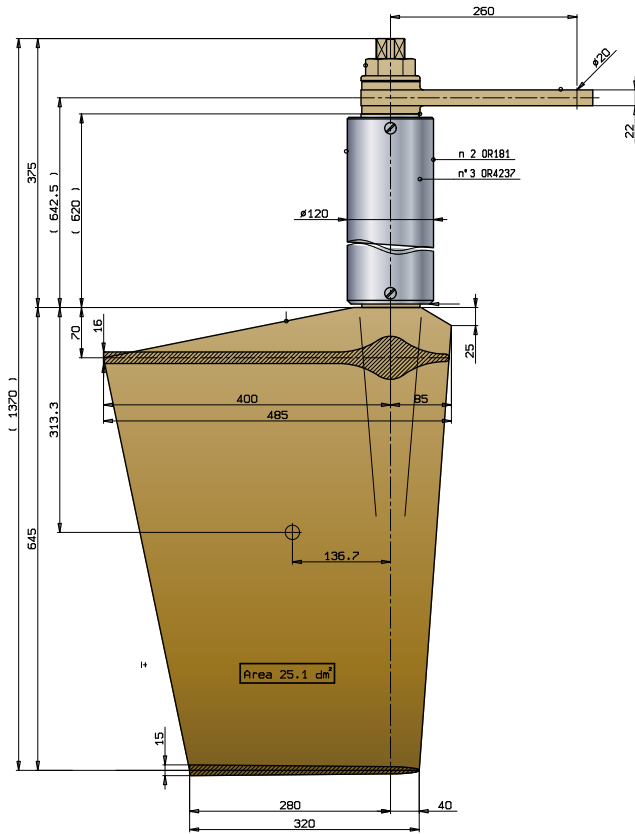

### LD 10.17 D55 L415

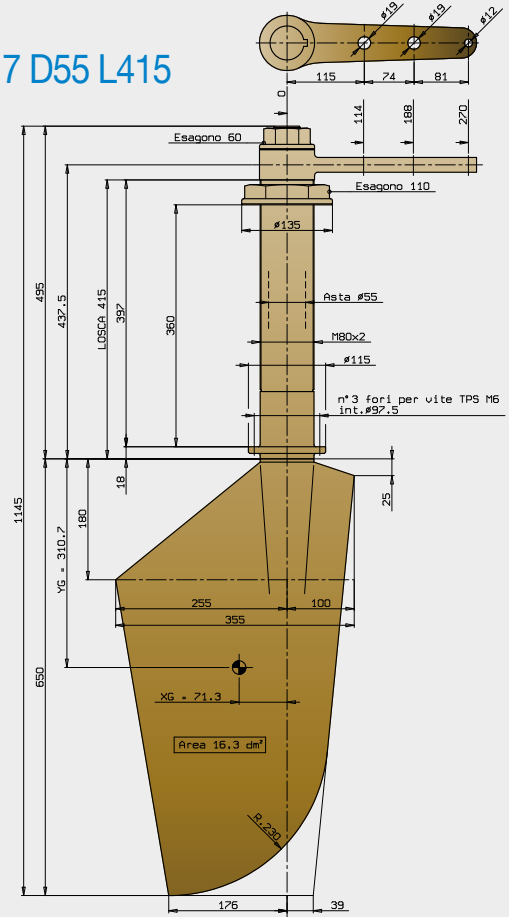

### LD 20.11 D45 L280

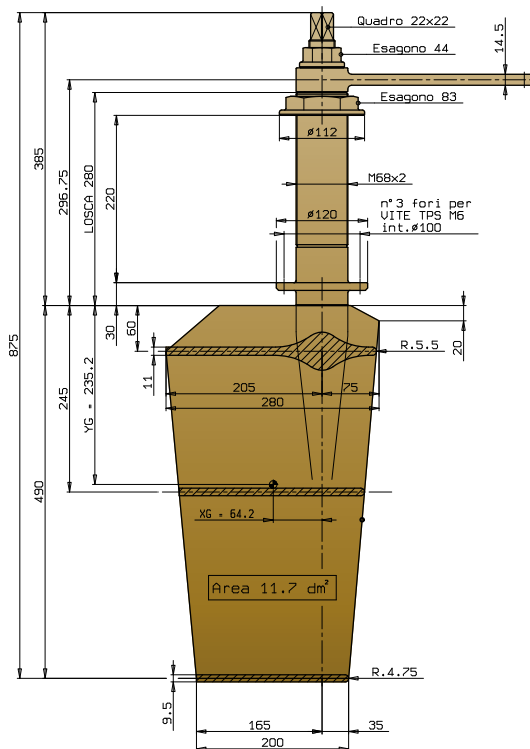

### LD 30.07 D40 L200

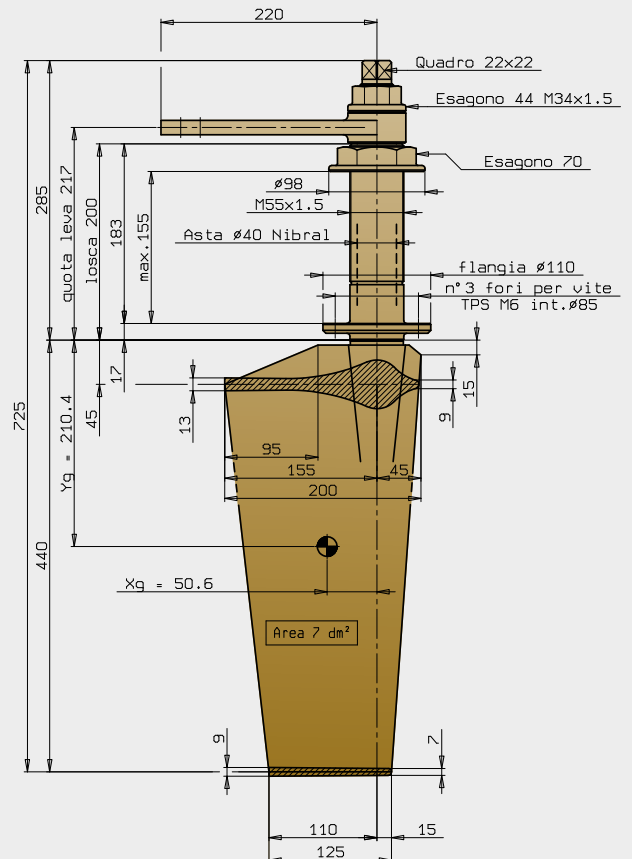

## RUDDERS

### LD 30.40 D90 L520

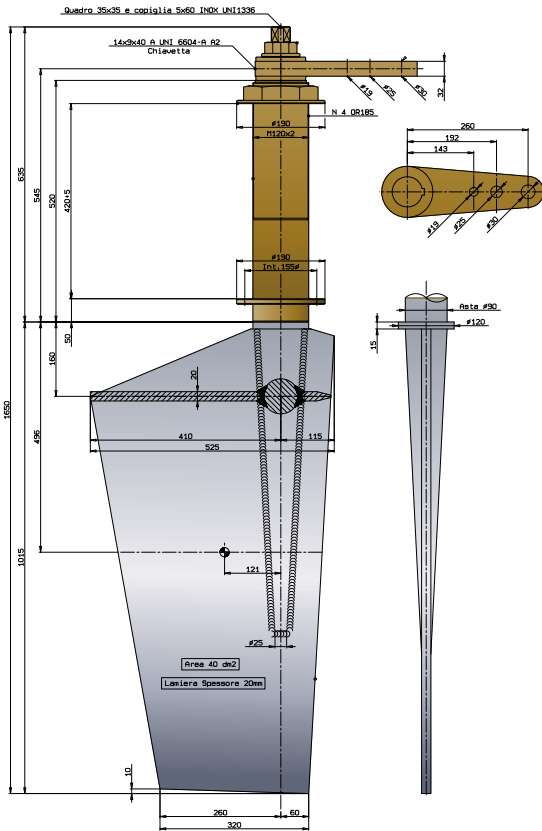

### LD 30.17 D60 L270

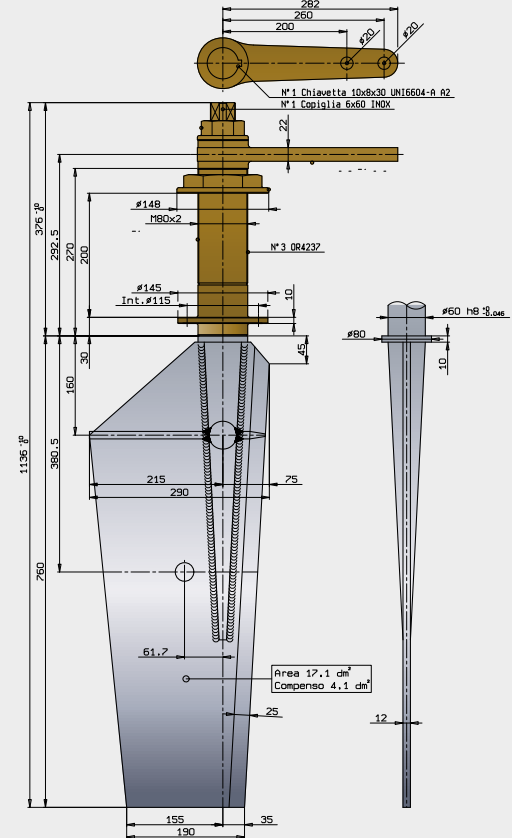

### LI 30.22 D60 L270

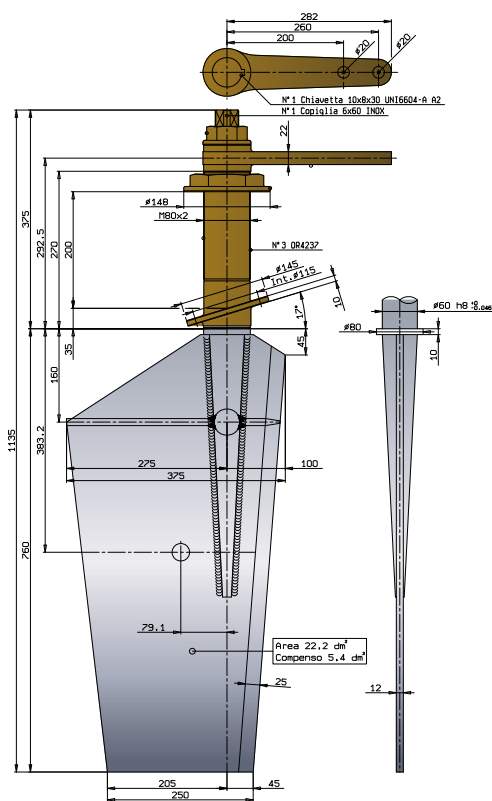

### LD 30.44 D90 L520

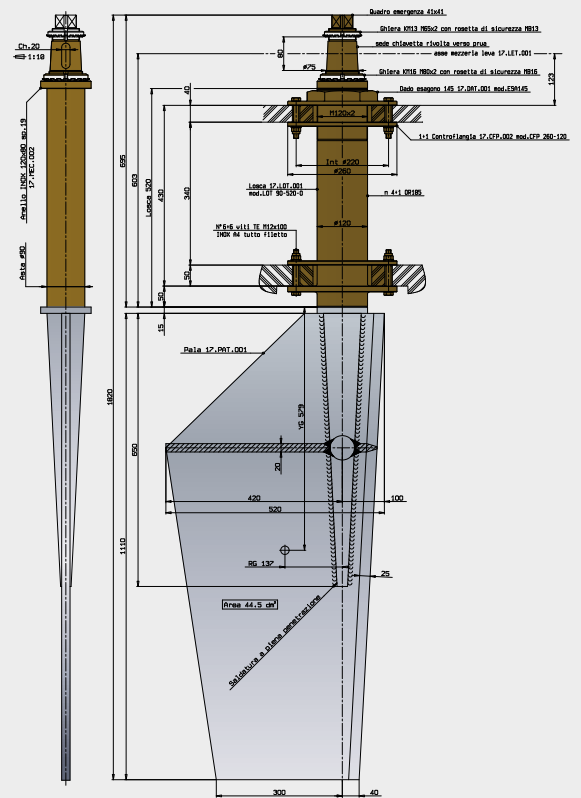



## RUDDERS

### LD 80.31 D70 L300

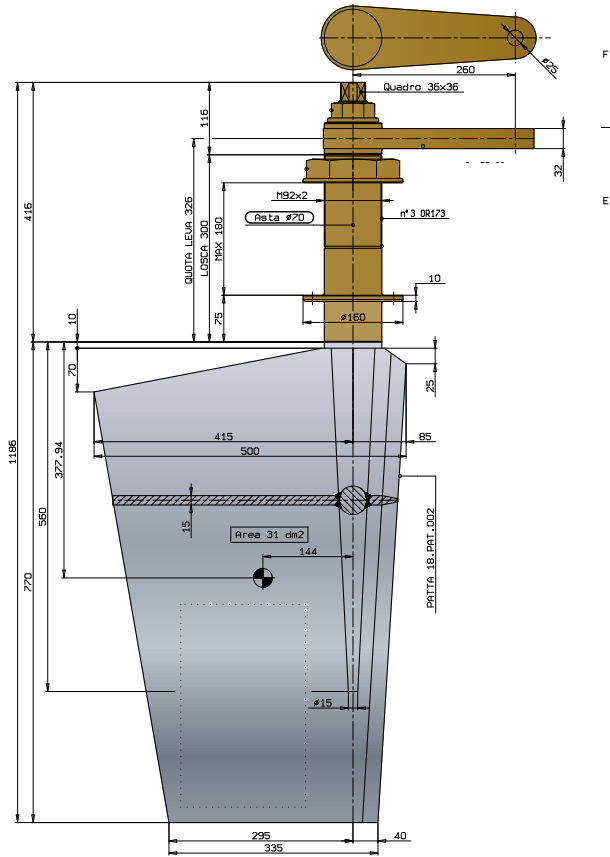

### LD 20.23 D60 L270

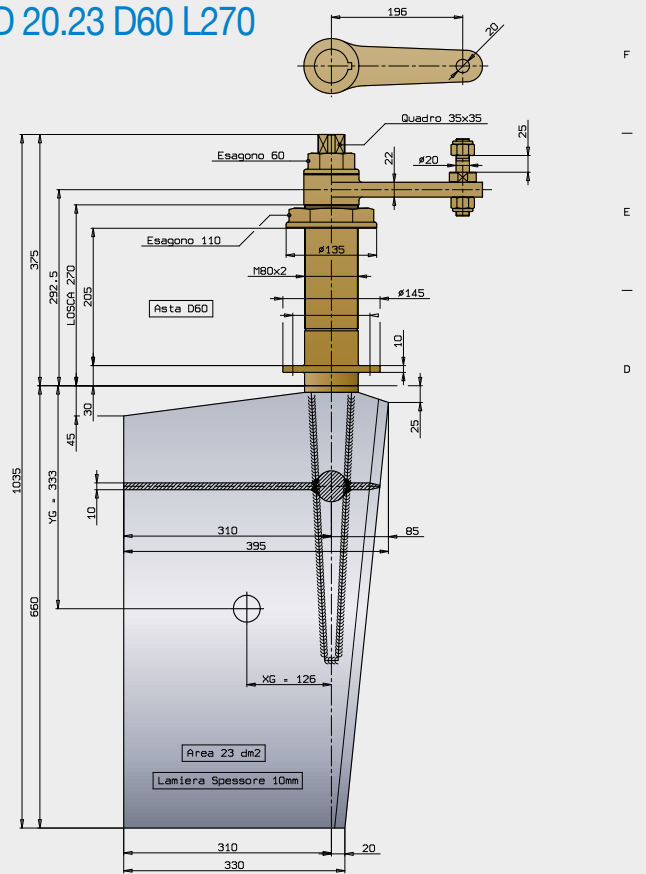

### LD 71.34 D100 L482

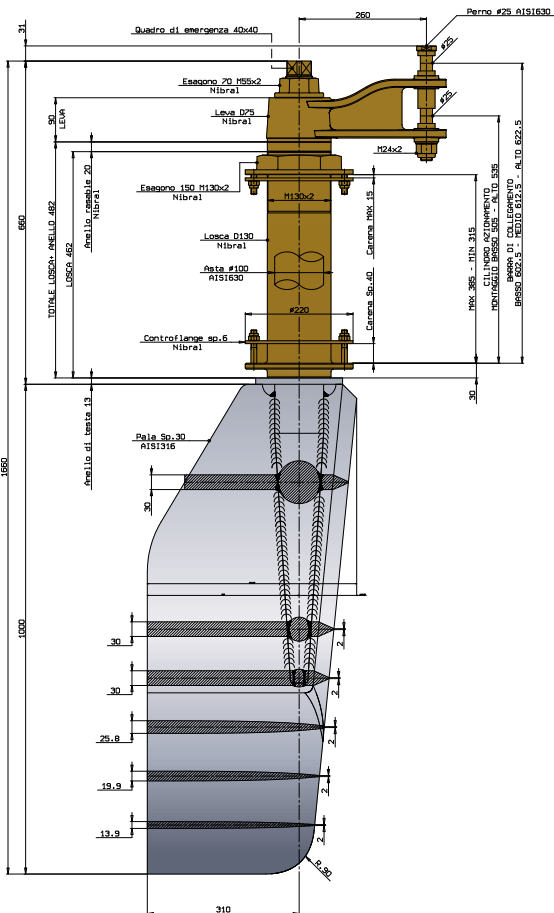

### LD 30.22 D60 L370

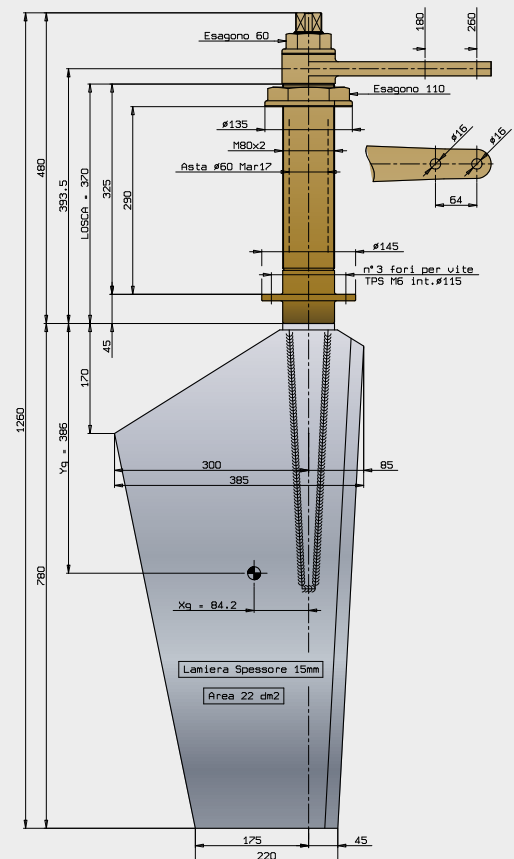

## RUDDERS

### LD 30.13 D40 L280

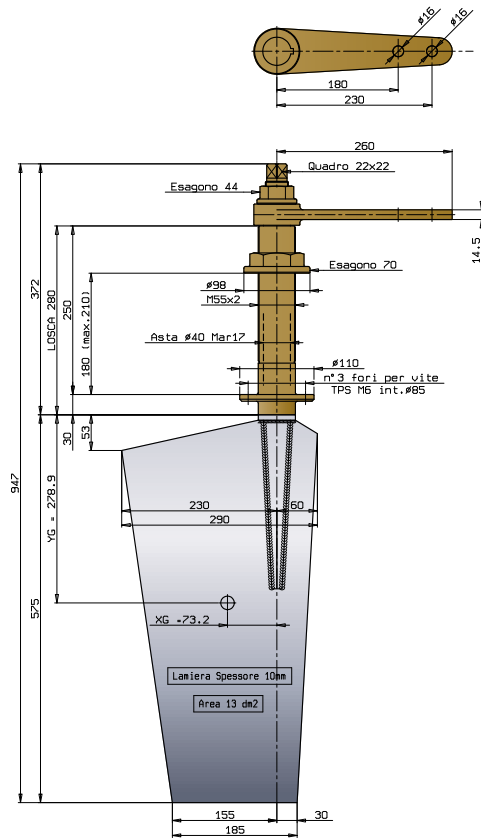

### LR 20.32 D55 L785

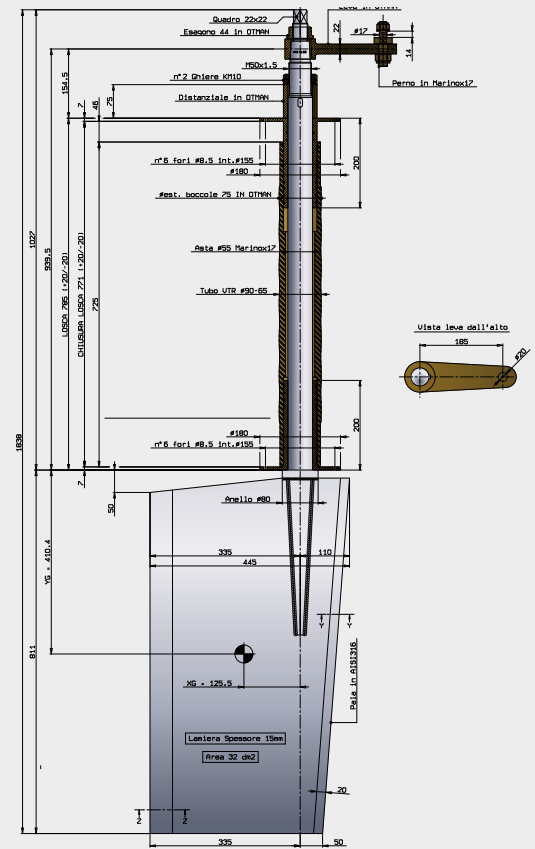

### CD 60.22 D60 L250

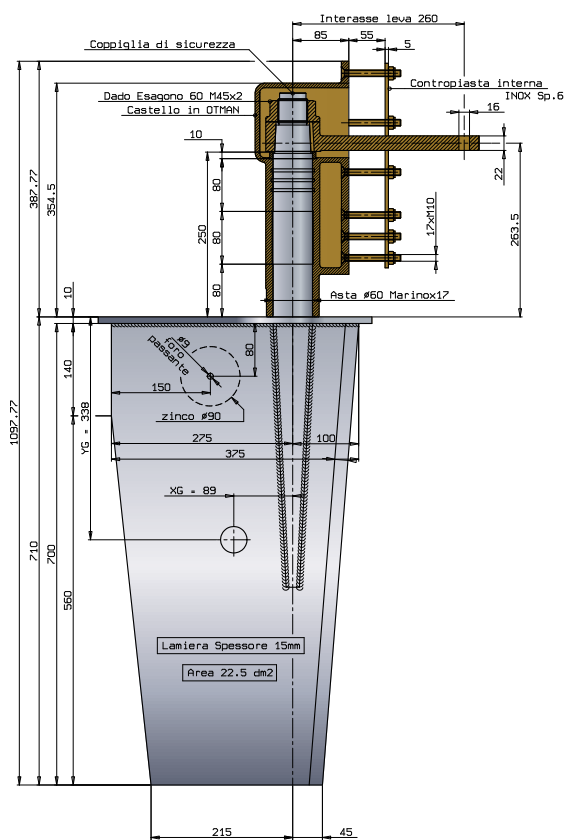

### LD 30.17 D50 L280

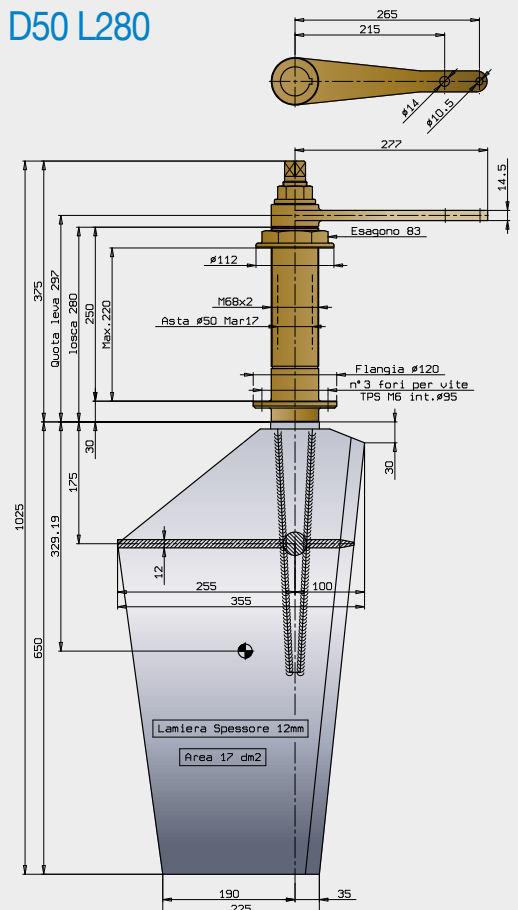

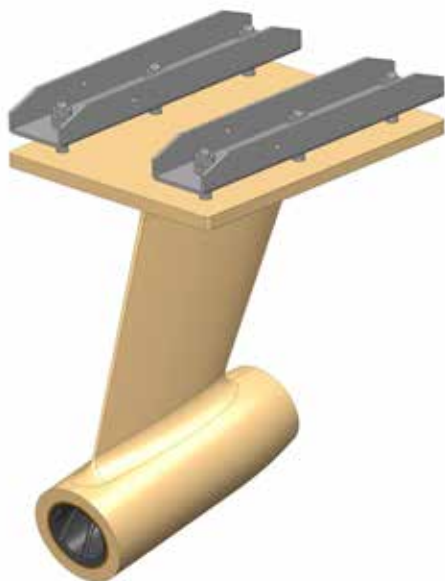

Supporti per asse portaelica realizzati su misura in base alle dimensioni richieste dal cliente. Disponibili in ottone al manganese (OTS2 per eliche), bronzo all'alluminio (Nibral) o in acciaio INOX fuso (AISI316). Adatti per imbarcazioni con omologazione CE, possono essere dimensionati secondo le regole dei più comuni registri navali e accompagnati dal certificato 3.2 Sempre completi di boccia idrolubrificata, su richiesta possono essere fornite anche le viti per il montaggio e le contropiastre interne allo scafo.

*Custom propeller shaft brackets according to the dimensions requested by the customer. Available in manganese brass (OTS2), aluminum bronze (Nibral) or cast stainless steel (AISI316). Suitable for boats with CE approval, they can be sized according to the rules of the most common naval registers and accompanied by the 3.2 certificate. Always supply with hydro-lubricated bushing, on request the screws for assembly and the counterplates inside the hull can also be supplied.*

**Supporto Base rettangolare con piastra di fissaggio**  
T-Bracket with mounting plate

**Supporto a resinare**  
VTR bracket



**Dritto a 90°**  
Straight



**Inclinato per seguire l'angolo di carena**  
Slanted to follow hull angle



**Con attacco a sezione NACA**  
NACA section mounting



**Con attacco rettangolare**  
Rectangular mounting



**Speciale, con pinna per protezione elica.**  
Special, with propeller guard

# Linee d'asse complete di timoni

COMPLETE SHAFTLINE / COMPLETE RUDDERS

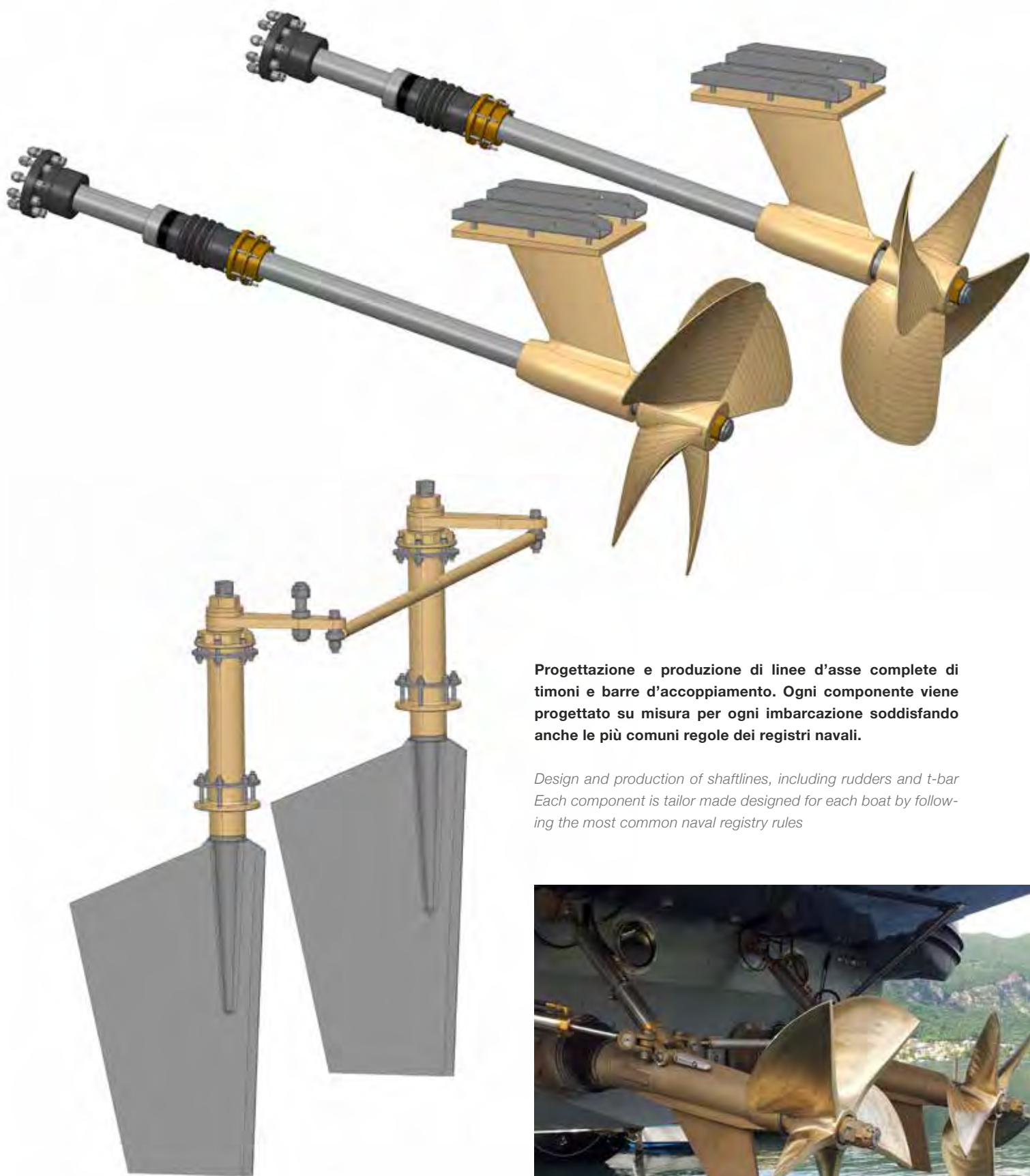

**Progettazione e produzione di linee d'asse complete di timoni e barre d'accoppiamento. Ogni componente viene progettato su misura per ogni imbarcazione soddisfacendo anche le più comuni regole dei registri navali.**

*Design and production of shaftlines, including rudders and t-bar  
Each component is tailor made designed for each boat by following the most common naval registry rules*



# Assi Portaelica e Flange Mancione

## PROPELLER SHAFT AND COUPLING FLANGE

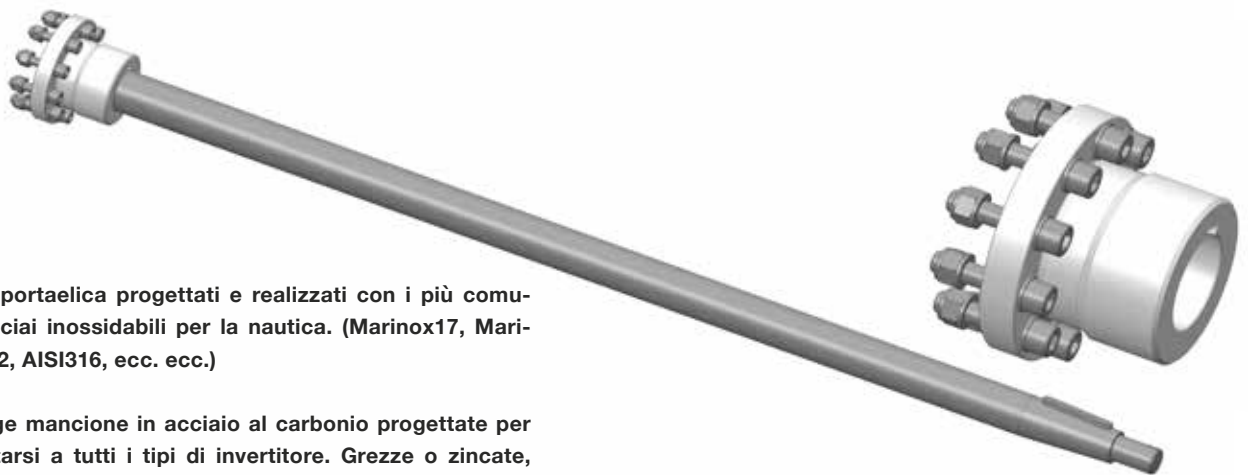

Assi portaelica progettati e realizzati con i più comuni acciai inossidabili per la nautica. (Marinox17, Marinox22, AISI316, ecc. ecc.)

Flange mancione in acciaio al carbonio progettate per adattarsi a tutti i tipi di invertitore. Grezze o zincate, possono essere anche fornite complete di viti per il montaggio.

*Stainless steel propeller shafts designed and made by common commercial materials (Marinox17, Marinox22, AISI316, ecc. ecc.)*

*Carbon steel coupling flange designed and made to fit each kind of transmission. Raw or galvanized, they can be supplied with mounting bolts*

# FLANGE PASSASCAFO

## TROUGHT HULL FLANGE

Flange passascafo in ottone realizzate su misura per ogni tipologia di tenuta meccanica presente in commercio.

*Trough-hull flange made by brass, tailor made designed for each kind of commercial mechanical seal*





**mze**  
MZ ELECTRONIC



**La ditta si riserva di modificare le caratteristiche degli articoli contenuti nel presente catalogo senza preavviso.**

*The company reserves the right to modify the characteristics of the articles in this catalogue without notice.*

## CONDIZIONI DI GARANZIA

Il consumatore è titolare dei diritti previsti dal D. Lgs. N. 206/2005 "Codice del consumo, a norma dell'articolo 7 della legge 29 Luglio 2003, n. 229" pubblicato nella GU n.235 del 08/10/2005 – Suppl. Ordinario n. 162, che restano impregiudicati dalle indicazioni di garanzia di seguito espresse: La garanzia è offerta da Mz Electronic srl, via Bainsizza 2 20900 Monza (MB) Italia.

Condizione indispensabile per far valere i diritti di garanzia è la presentazione a Mz Electronic dei seguenti documenti:

- Un documento attestante l'acquisto del prodotto (fattura)
- Numero di matricola del prodotto

Titolare del diritto di garanzia è l'acquirente o l'utilizzatore del prodotto. Tutti gli articoli sono garantiti per un periodo pari a 2 anni (due) dalla data di acquisto del prodotto.

### CONDIZIONI E LIMITAZIONI

1. La responsabilità di MZ Electronic è limitata alla riparazione o alla sostituzione di parti del prodotto difettoso; la garanzia non copre quindi tutte le spese accessorie che scaturiscono in seguito alla riparazione del vizio (montaggio, smontaggio, trasferte, fermo barca, ecc); tutte queste spese sono a carico dell'acquirente o dell'utilizzatore.

2. MZ Electronic non si riterrà responsabile in alcun modo per malfunzionamento del prodotto, perdite e/o danni risultanti da:

\* Utilizzo del prodotto per un'applicazione per la quale esso non è preposto o inteso \*Corrosione, degrado dovuto a raggi ultravioletti, usura e rottura \*Incapacità di utilizzo o manutenzione del prodotto secondo le indicazioni date da MZ Electronic ovvero, installazioni difettose o inadeguate del prodotto \*Cambi o alterazioni del prodotto \*Condizioni di lavoro che superino le capacità del prodotto o le condizioni di sicurezza elettrica dello stesso \*smontaggio anche parziale del prodotto

3. Il prodotto soggetto a richiesta di garanzia deve essere inviato al rivenditore o a MZ Electronic, se direttamente fornito, per controllo ed il rientro deve comunque essere autorizzato per iscritto da MZ Electronic.

4. Questa garanzia non copre spese accessorie sostenute per indagini, rimozione, trasporto o installazione del prodotto.

Ogni intervento eseguito da personale non autorizzato da MZ Electronic renderà nulla detta garanzia. I prodotti MZ Electronic sono intesi ad uso esclusivo in ambiente marino. MZ Electronic declina ogni responsabilità dovuta ad ogni altro uso.

### ECCEZIONI

La copertura di questa garanzia è limitata al periodo di un anno dalla data di acquisto da parte dell'utilizzatore, nel caso in cui il prodotto o parte di esso venga utilizzato per:

- Prodotti ad uso commerciale e/o charter.

### RESPONSABILITA'

La responsabilità di MZ Electronic riguardante questa garanzia, esclude ogni altra garanzia o responsabilità nella misura consentita dalla legge. In particolare: MZ Electronic non si riterrà responsabile per: \*Perdita di fatturato o profitto diretto o indiretto, e consequenziali perdite economiche \*Danni, costi o spese sostenute da terzi \*Danni a barche o strumentazioni \*Morte o ferite (a meno che non siano causate da negligenza da parte di Mz Electronic). Questa garanzia elenca gli specifici

diritti consentiti da MZ Electronic; essi possono differire a seconda delle leggi vigenti nei differenti paesi. L'acquirente inoltre può avere altri diritti legali, che possono variare di paese in paese.

### PROCEDURA

La segnalazione di richiesta di assistenza in garanzia deve essere fatta rapidamente in forma scritta dall'utilizzatore finale al rivenditore, che provvederà a contattare MZ Electronic, o a MZ Electronic Via Bainsizza 2, 20900 Monza, Italia, in caso di vendita diretta. Prova di acquisto e autorizzazione da MZ Electronic sarà richiesta prima di effettuare qualsiasi intervento di riparazione.

### IMPORTANTE

Le caratteristiche tecniche ed estetiche degli articoli in visione sul nostro catalogo sono indicative e possono variare in qualsiasi momento. MZ ELECTRONIC declina ogni responsabilità per possibili inesattezze contenute nel catalogo, dovute ad eventuali errori di stampa o trascrizione: MZ ELECTRONIC si riserva il diritto di apportare ai propri articoli quelle modifiche che riterrà necessarie o utili senza pregiudicarne le caratteristiche essenziali.

### LEGGE APPLICABILE E FORO COMPETENTE

L'esecuzione, l'interpretazione e tutte le questioni pertinenti la validità e gli effetti della presente garanzia saranno comunque determinate e regolate dalla legge italiana.

Per ogni controversia sarà foro competente esclusivo il Foro di Monza-Italia.

### TERMS OF WARRANTY

The consumer is granted the rights established by Legislative Decree no. 206/2005 – "Consumer Code, pursuant to Article 7 of Law no. 229 dated 29th July 2003", published in the Official Gazette no. 235 of 8th October 2005 – Ordinary Supplement no. 162, which shall remain unaffected by the Terms of Warranty set out below.

The warranty is issued by Mz Electronic Srl headquartered at Via Bainsizza 2 – 20900 Monza (MB), Italy.

The following documentation must be submitted to Mz Electronic in order to asserting any claims under warranty:

- A document proving purchase of the product (invoice);
- The product serial number.

The purchaser or user of the product is the owner of the warranty. All items are covered for a period of 2 (two) years from the date of product purchase.

### CONDITIONS AND LIMITATIONS

1. MZ Electronic's liability extends only to the repair or replacement of parts of the defective product. The warranty does not cover any incidental costs arising from the repair of the defect (assembly, disassembly, transport, downtime, etc.), which are to be borne by the purchaser or user.

2. In no way shall MZ Electronic be liable for product malfunctions, loss and/or damage resulting from: \* Utilisation of the product in

a manner not foreseen or intended; \* Corrosion, degradation due to ultraviolet rays or wear and tear; \* Inability to use or maintain the product in accordance with the instructions provided by MZ Electronic or due to faulty or inadequate installation of the product; \* Modifications to or alterations of the product; \* Working conditions that exceed the capacities of the product or its electrical safety conditions; \* Dismantling of the product, even partial.

3. The product subject to any claim under warranty must be sent to the dealer or, if supplied directly, to MZ Electronic for inspection. Any returns must in any case be authorised in writing by MZ Electronic.

4. This warranty does not cover incidental expenses incurred in investigating, removing, transporting or installing the product. Any work carried out by personnel not authorised by MZ Electronic shall render this warranty null and void. MZ Electronic products are intended only for utilisation in marine environments. MZ Electronic accepts no liability for any other use.

### EXCEPTIONS

The duration of this warranty is limited to a period of one year from the date of purchase by the user, whereby the product, or part thereof, is used for: - Commercial and/or charter use.

### RESPONSIBILITY

MZ Electronic's liability in respect of this warranty excludes any other guarantee or liability to the extent permitted by law. In particular, MZ Electronic cannot be held liable for: \* Direct or indirect loss of turnover or profit along with any consequential economic loss; \* Damages, costs or expenses incurred by third parties; \* Damage to boats or equipment; \* Death or injury (except whereby caused by Mz Electronic's negligence).

This warranty lists the specific rights granted by MZ Electronic, which could differ in accordance with the laws in force in various countries. The purchaser may also have other legal rights that may vary from country to country.

### PROCEDURE

Claims under warranty must be made promptly in writing by the end user to the dealer, who will in turn contact MZ Electronic. For direct sales, claims are to be made to MZ Electronic at Via Bainsizza 2 – 20900 Monza, Italy. Proof of purchase and authorisation from MZ Electronic shall be required before any repair work is carried out.

### IMPORTANT

The technical and aesthetic characteristics of the items shown in our catalogue are indicative and may change at any time. MZ Electronic accepts no liability for any possible inaccuracies in the catalogue due to printing or transcription errors. MZ Electronic reserves the right to make any changes to its items whereby considered necessary or useful, without affecting their basic characteristics.

### APPLICABLE LAW AND JURISDICTION

The effects, interpretation and any matters pertaining to the validity and extent of this warranty shall in any event be determined and governed by Italian law.

Any dispute shall fall under the exclusive jurisdiction of the Court of Monza, Italy.

[www.mzelectronic.it](http://www.mzelectronic.it)

[info@mzelectronic.it](mailto:info@mzelectronic.it)

**mze**  
MZ ELECTRONIC

**mze**  
MZ ELECTRONIC

**italwinch**  
S.p.A.

**ORVEA**



**progettoelica**

**SBM**

MZ Electronic S.r.l.

Via Bainsizza, 2 - 20900 Monza (MB) Italy

phone +39 039 21 48 126 fax +39 039 21 46 244