

PLASTIMO
happy boating to you!

Safety

Distributed in the USA by  **BAINBRIDGE**
INTERNATIONAL



www.bainbridgeintusa.com

Guillaume Carretil ©

Safety harnesses



JM Lot©

Try your harness on

A safety harness is a personal piece of equipment : the straps must be perfectly adjusted to your body size. Try it on, adjust it, get to recognise every strap. If you wear your harness with an inflatable lifejacket, the harness must be worn under the lifejacket.

Keep your harness in good condition

A safety harness is a fundamental piece of equipment for your safety : as opposed to a lifejacket, on which buoyancy can be tested and possible ageing signs are visible, a harness can lose some of its original qualities without there being any visible signs.

- Rinse it with fresh water after use.
- Check the seams regularly.
- Never store it in a damp locker.
- Discard and replace systematically a harness showing evidence of wear and tear or a harness which has been submitted to tension.
We recommend that racers should replace their harness every year, in view of their intensive use and exposure to UV-rays.
- Never use a harness for any other purpose than the one which it is designed for.



Double adjustable harness
66829

Ergonomic double adjustable safety harness. Quick and easy adjustment : simultaneous on waistband and shoulder straps. X-shaped back for added comfort and freedom of movement. When harness is tight-fitted, the excess strap length is neatly rolled on waistband with velcro. Once worn, you don't feel it. Bi-colour black and neon green for increased visibility. Attachment point for tether : textile loop with sewn retro-reflective thread to optimize visibility at night.

- ISO12401 certified.
- World Sailing - OSR compliant.
- Textile loop resistance : 2 000 DaN – 2 040 kg.
- Chest size min/max : 80-130 cm (20 kg min.).
- Wide strap : 45 mm.
- Weight : 250 g.
- Supplied in a mesh bag.

With optimized adjustable system, this harness fits all body types including junior size as from 20 kg.



X-shaped back : quick and easy adjustment.



Simple adjustable harness
66830

Adjustable waistband safety harness. Attachment point for tether : textile loop with sewn retro-reflective thread to optimize visibility at night.

- ISO12401 certified.
- World Sailing - OSR compliant.
- Textile loop resistance : 2 000 DaN – 2 040 kg.
- Chest size min/max : 80-120 cm.
- Wide strap : 45 mm.
- Weight : 250 g.
- Supplied in a mesh bag.



Simple adjustable harness & tether pack

- Harness & 1 st. steel safety hook : **67037**
- Harness & 2 st. steel safety hooks : **67038**



J.M. Liot ©

Plastimo-SNSM* tether

Sharing the same commitment to safety at sea, Plastimo innovates with SNSM*

3-hook tether SNSM*-Plastimo 67494

When developing a new product, Plastimo systematically teams with experts for extra technical input and live experience. In the case of a harness tether, whose advice could be more relevant than the national search and rescue squads ? So Plastimo was proud and thrilled when the French National Lifeboat & Lifeguard Society (SNSM) asked our R & D teams to co-develop and manufacture the tether that rescue teams will use in their mission : a technical and really innovative product stemmed from this cooperation.

This tether is **now available to all sailors**.

- One-piece tether : while tethers are traditionally constructed from two webbing pieces, the Plastimo-SNSM model is built from one single webbing strap. This exclusive design provides optimum safety and added performance feature.
- Flexible tether includes a sewn-in retro-reflective thread to optimize visibility at night.
- Double safety aluminum hooks with anti-slip-grip treatment : a yellow hook secured to the harness and two orange hooks connected to the jackline or fixed point on the boat. Orange hooks feature an additional protection against rubbing and chafing through a hard-anodizing process.
- **One short straight strand 100 cm, one long elastic strand 110-175 cm.**
- Two strain indicators : when the tether is submitted to a heavy load, the strain indicator exposes a label indicating that the tether should be replaced.
- Supplied in a mesh bag.
- Breaking strain : 1 650 kg.
- Weight : 570 g.

*French National Lifeboat & Lifeguard Society



World Sailing – OSR compliant



Discover the Plastimo tether assortment
www.plastimo.com

With three different kinds of hooks combined with flat, elastic or double tethers, the Plastimo range offers 12 possible combinations, meeting all sailors' needs.



Tethers



A tether is the indispensable accessory which makes an inflatable lifejacket a fully featured safety equipment. Provided of course, that you have originally selected a lifejacket with integrated harness : the only version providing the adequate resistance and featuring a loop for the tether. All the Plastimo tethers are equipped with automatic closing safety hooks to prevent accidental opening. Polyester flexible tethers with retro-reflective thread to optimize visibility at night. Flat, elastic or double – 23 mm width – version. Strain indicator. ISO12401 certified. Supplied in a mesh bag.

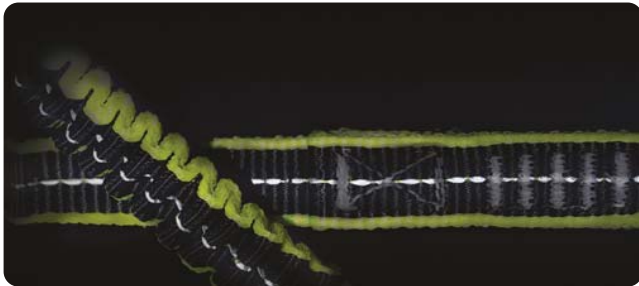

Retro-reflective thread



Charge indicator

When the tether is submitted to heavy load (ex. man over board), the strain indicator exposes a label indicating that tether should be replaced.



St. steel safety hook

Double safety.
Opening : 14.5 mm.
Weight : 145 g.



Aluminium safety hook with ferrule

Easy opening and closing through the ferrule.
Lightweight and compact.
Opening : 20 mm.
Weight : 100 g.



Premium aluminium safety hook

Robust safety hook with safety bar. Superfast opening and closing in a single action.
Opening : 22 mm.
Weight : 130 g

		St. steel safety hook		Aluminium safety hook with ferrule		Premium aluminium safety hook		Tether length			
		Ref.	Weight	Ref.	Weight	Ref.	Weight				
Flat tethers	1 safety hook	A	66834	215 g	B	66833	175 g	1.5 m			
	2 safety hooks	C	66838	345 g	D	66837	275 g				
Elastic tethers	1 safety hook	E	66836	225 g	F	66835	185 g	G	66866	215 g	1 m extends to 1.5 m
	2 safety hooks	H	66840	355 g	I	66839	285 g	J	66867	340 g	1 m extends to 1.5 m
Double tethers*	3 safety hooks	K	66865	550 g	-	-	-	L	66842	515 g	1 m flat line + 1 m extends to 1.5 m*

* World Sailing – OSR compliant.



World Sailing – OSR compliant

Jacklines



Being made of fibres, jackline webbing is subject to ageing – even with no visible signs – due to UV-rays, sea water and temperature. Ideally, jacklines should be taken down, rinsed and stored in a dry place for wintering. Still, we strongly recommend to replace them regularly ; to be more specific, jacklines must be replaced after a cumulated period of 2 years of outdoor exposure.



Jackline with retro-reflective thread.



Retro-reflective strap jacklines

Ultra-flat polyester webbing, 26 mm wide. Retro-reflective thread optimizes visibility at night. Fixing loops. Breaking strain 2 400 DaN (2 450 kg).

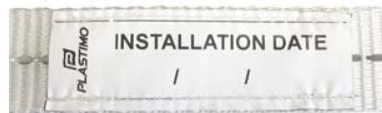

Label on the jackline to write the date of the first use.

Sold by the pair, shackle not included.

Length	White, retro-reflective thread
6 m	66984
7 m	66985
8 m	66986
9 m	66987
10 m	66988
12 m	66989
14 m	66990

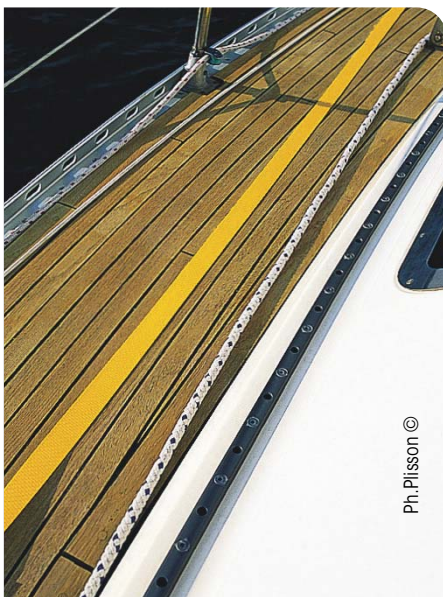

Ph. Plisson ©

Sold by the pair, shackle not included.

Classic strap jacklines

Ultra-flat polyester webbing, 30 mm wide. Breaking strain 2 000 DaN (2 040 kg).

Length	White	Yellow
6 m	39447	36214
7 m	39448	36215
8 m	39449	36216
9 m	39450	36217
10 m	39451	36218
12 m	66982	66981
14 m	66983	62102

Man over board

RESCUE

The Rescue range consists of 4 products designed to contribute to the recovery of a man overboard.

Once the product is deployed, the boat simply circles the casualty so that he/she can grab the buoy without swimming and can then be pulled back to the boat.

Rescue Sling, Rescue Buoy and Rescue Buoy offer an extra safety feature : the retrieval line is coiled on a reel. This avoids the line getting entangled and allows a swift and reliable repacking.

This extremely simple procedure also allows the crew to drill and get acquainted with the product, therefore more confident in the rescue process.

Product	Performance	To rescue team / haul in	Providing buoyancy	Hoisting casualty back aboard
Rescue Line		✓	-	-
Rescue Buoy		✓	145 N	-
Rescue Ring		✓	155 N	-
Rescue Sling		✓	95 N	✓



©Th. Martinez/Sea&Co

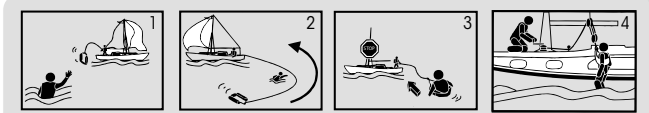

The clever and exclusive spool system offers a definite safety plus, as it prevents the line from getting entangled. Besides, it allows a swift and easy "repacking" procedure : another good reason to urge the skipper to drill the crew.

Rescue Sling®

- Yellow : 27027
- White : 35713

Complete rescue gear, which delivers flotation to the victim and provides a means to hoist the person back aboard (with the help of a lifting tackle or halyard winch if necessary). The clever and exclusive design of the Rescue Sling consists in the retrieval line which is coiled on a reel: this avoids the line tangling or fouling, and makes the Rescue Sling the most efficient man over board recovery gear.



Patented



- Buoyancy of flotation belt : 98 N.
- 40 m of floating line.
- Storage bag with clips for rail attachment.
- Dimensions : height 50 cm, width 30 cm, thickness 20 cm.
- Weight : 1.7 kg.
- Breaking strain of line : 400 kg.
- Breaking strain of flotation belt : 700 kg.

Accessories



- Flashlight : 2263071

- Spare cover
Yellow : 38153
White : 38151



World Sailing - OSR compliant.



Rescue Line® 27020

Throw bag heaving line, very simple to operate : a 20 m retrieval line stowed in a bag, allowing to connect the survivor to the boat. Equally useful in many circumstances, such as getting a line to a dock, and also in many river leisure activities, such as canoeing, rafting, etc. The Rescue Line is weighted, so that it can be thrown with accuracy at a reasonable distance, even against strong winds. It features a grab loop at both ends, enabling both the rescuer and the survivor to remain attached to the line.

- 20 m floating line (Ø 7.5 mm*).
- Bright yellow colour for good visibility.
- Weight : 500 g.
- Breaking strain of line : 400 kg.

Accessories

- **St. steel basket for Rescue Line : 30766**
For pulpit mounting.
Designed for tube Ø 18.5 to 25.5 mm.
- **Spare bag : 28367**



To be used as a complement : does not replace an active radar reflector

Tube-type radar reflectors

Clever shape : creates minimum windage and also less chafe on gear.

	Model	Ref.	Max. reflective area	Dimensions	Weight
A	Sailboat	25586	2 m ²	58 cm long Ø 5 cm	250 g
	Features a shroud groove	39099	4 m ²	59 cm long Ø 10 cm	900 g
B	Powerboat	25587	2 m ²	56 cm long Ø 5 cm	300 g
	Features a mounting bracket	29496	4 m ²	56 cm long Ø 10 cm	1100 g

IOR dan buoys

World Sailing regulations require the "marking of a man overboard for yachts sailing offshore".

Inflatable IOR dan buoy



©Th.Martinez / Sea&Co.



Inflatable IOR dan buoy

MOB pole for crew-overboard visibility, provides 150 N buoyancy.

- **Yellow canister : 63455**
- **White canister: 61073**

Dan buoy pole

Yellow nylon, polyurethane coated.
Height above water (inflated pole) : 1.98 m.

Features :

- adjustable webbing sling seat for man-over-board to rest on,
- grab handle,
- 0.75 cd automatically activated light, 8-hour battery life,
- red and yellow flag (32 x 20 cm),
- retro-reflective tapes (200 cm²),
- signalling whistle,
- rigid ballast with V-shaped batten structure, acting like a keel for optimum stability,
- drogue anchor (28 x 28 cm) to help resist drifting.

Canister

- Torpedo-shaped canister in ABS plastic, height 49 cm x Ø 13 cm.
- Weight : 3.8 kg.
- Optional pushpit fixing kit.

**MADE BY
PLASTIMO**



World Sailing - OSR compliant

Mounting the canister and deploying the IOR dan buoy :

The ABS case containing the IOR dan buoy is positioned on the boat's pushpit (optional kit: 415010).

The canister is attached to the holder by a lanyard.

In the event of a man overboard, throw the canister towards the victim.

Deployment will occur when lanyard is fully tensioned.

(which is no longer connected to the support).

The case floats, attached to the buoy.



Webbing sling seat and grab loop.

Options & Accessories



- Stern rail mounting kit : **415010**
For optimal mounting, provide 2 mounting kits.



- Gas re-arming kit : **50374**
60 g gas cylinder



- Light replacement kit : **63456**
0.75 cd light + mounting accessories for dan buoys 40203, 177788, 63455 and 61073

- Canister alone :
White : **52240**
Yellow : **53417**
For dan buoys ref. : 40203, 177788, 63455 and 61073

Checking and servicing your inflatable dan buoy or lifebuoy

To ensure that your inflatable dan buoy or lifebuoy is fully operational when needed, we strongly recommend that you check them and have them serviced at regular intervals.

- Before putting off to sea, you can easily inspect their general condition visually, by checking the main components (container, inflatable chamber, retro-reflecting tapes, CO₂ gas cylinder – check that the cylinder is tightly screwed –, firing head, safety light – check the date of the light –). Replace the re-arming kit if necessary.
- A complete servicing session conducted at regular intervals includes checking the inflation system and the airtightness of the chamber.

Plastimo recommends to have one spare kit for each dan buoy and lifebuoy on board.

World Sailing - OSR 4.22 : Man overboard.

The complete equipment of a boat includes 2 lifebuoys equipped with :

- 1 whistle (ref. 52937)
- 1 floating anchor (ref. 25354)
- 1 self-igniting light (ref. 2263071)
- 1 bag of fluorescein (ref. 38861)
- One reflective material (ref. 60906)

One of the buoys must include an IOR pole with flag. The pole must be permanently deployed or be capable of automatic deployment.

At least one of the two buoys must have permanent buoyancy.

Rigid IOR dan buoys

World Sailing - OSR compliant



Telescopic IOR dan buoy

- Orange float : **55664**
Ergonomic design and superior stability.
Complies with the racing regulations.

Features :

- 1 fibreglass telescopic dan buoy with 1/4 twist fastening.
- 1 ergonomic and shockproof cylindrical PVC floatation buoy (height 360 mm, Ø 180 mm/80 mm).
- 1 man-over-board red and yellow flag 480 x 330 mm.
- 4 m of floating rope to attach to a lifebuoy.
- 1 built-in stainless steel ballast.
- 1 clip and lanyard to keep the flag rolled up.

To obtain a dan buoy with light, simply add the optional light kit. When fitted, light is situated 2.30 m above the waterline. Powered by a 9 V battery.

When the dan buoy is thrown into the water, the lanyard detaches the clip from the light, which then activates automatically the light.

To fit the light to the dan buoy, simply push the bayonet fitting into the top of the dan buoy.

Height extended	Height telescoped	Height above water
3.52 m (3.64 m with optional light kit)	1.95 m (2.07 m with optional light)	2.30 m (2.42 m with optional light)

Inshore dan buoy

176928

Black GRP tapered pole 2.14 m long.

Yellow encapsulated float.

Yellow plastic dipped lead weight.

Flag and 25 mm band of retro-reflective tape.

3 m of Ø 8 mm floating line.

Options & Accessories

- Telescopic dan buoy holder : **56397**
316L stainless steel, totally maintenance-free. Fits easily on Ø 18.5 to 25.5 mm pushpits or backstays. Spare clip alone (x1) : 37030
- Fixed light kit : **16205** (battery not incl.)
- Spare bulb for fixed light kit : **66499**
- Spare flag : **10742**
- Fixing clip for flag : **16703**



56397

Lifefloats

Plastimo lifefloats

Polystyren foam enclosed within a strong PVC cover, high frequency welded with zip.

Fitted with braided rope reeved through reinforced welded fairleads.

Do not use life floats as cushions.

Use	Ref.	Buoyancy	Weight	Dimensions
2 persons	65199	323 N	1.7 kg	45 x 45 x 16.5 cm
3 persons	65200	451 N	2.3 kg	60 x 47 x 16.5 cm
4 persons	65201	598 N	3.2 kg	74 x 50 x 16.5 cm
6 persons	65202	902 N	4.5 kg	100 x 60 x 16.5 cm



Double cushion

Triple cushion



Buoyant cushions

Light polyethylene foam protected by a durable polyester fabric cover.

Great to sit, also provides efficient buoyancy aid in the event of a Man Over Board.

Peripheral straps facilitate grabbing.

Easy care : cover is washable with fresh water and can be sun dried.

Model	Use	Ref.	Colour	Buoyancy	Weight
Double	1 person	70600	Red	150 N	0.620 kg
Double	1 person	70601	Navy blue	150 N	0.620 kg
Triple	2 persons	70602	Red	300 N	0.970 kg

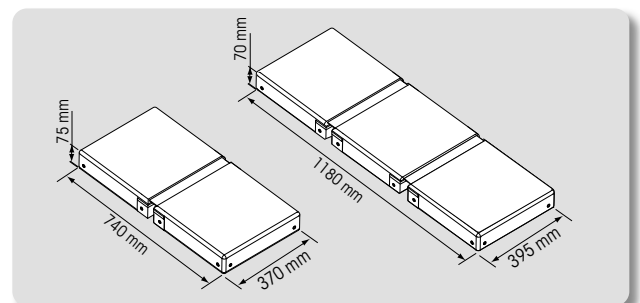

Lifeguard lifebuoy

70620

Designed for sea or fresh water rescue.

Its shape and weight have been defined to facilitate a precise throw towards the person in difficulty.

Once the victim is attached to the buoy, the rescuer can pull the victim towards the boat or the shore.

Made of polyethylene with polyurethane foam filling.

Delivered with traction line and shoulder strap.

Dimensions : 670 x 230 x 135 mm.

Weight : 1.4 kg.

Signalling

Sound



Gas fog horn

Delivers a 115 dB blast at 2 m distance. Clipper-on canister. Ozone friendly.

Type of gas	Fog horn, complete	Capacity	Spare canister
Inflammable	64388	230 ml	64389
Non flammable	64390	200 ml	64391



Fog horn 16183

Highly resistant polyamide. Length : 30 cm. Ø 8 cm.

Visual



Motoring cone

Indicates use of motor on a sailing boat. Folds flat.

Dimensions, when folded	Ref.
47 x 33 cm	39552

Whistle 52937



Polypropylene whistle, required on all lifejackets as from 100 N buoyancy. Dimensions : 7.3 x 1.9 x 2 cm (L x H x W). Weight : 5 g.



Trump and Mini-Trump

Combines the powerful blast of sound of a gas fog horn, with the simplicity of a mouth horn : delivers over 100 dB with no effort. Operates on the vibration of a plastic diaphragm.

Hard-wearing, colourfast, nature-friendly and economical. Virtually can't be lost, because it floats.

The Mini-Trump is the more compact version.

Model	Ref.	Ø	Weight	Length	Description
TRUMP	27180	70 mm	140 g	195 mm	Comes in a tube canister, with lanyard and 2 spare diaphragms.
MINI-TRUMP	37894	50 mm	50 g	Adjustable from 87 to 163 mm	Shell pack.

Brass bell 417988

Removable bell in polished brass, Ø 300 mm. Compulsory on all crafts 20 m long and more. Complies with COLREG 72 specifications.



Anchor ball

Internationally recognised signal for use when at anchor. Folds flat for easy storage.



Ø	Ref.
30 cm	16185
35 cm	39553

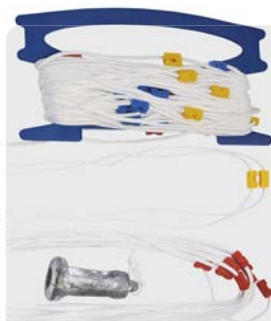

Hand lead lines

- 30 m : **417053**
- 50 m : **39258**

Ø 4 mm nylon rope with colour toggle every metre and colour change every 10 metres.

0.615 kg sounding lead weight with recess for wax.

Total weight : 905 g for 30 m model, 1 030 g for 50 m model.

Lifebuoy lights

**MADE BY
PLASTIMO**



Patented

Floating fixed light

- Without bracket : **57718**
- With bracket : **57719**

Designed to complement the horseshoe buoys.

- Visibility radius : 360°.
- Optimal visibility thanks to the position of the lighting optic 10 cm above the water.
- Autonomy : > to 6 hours.
- Light intensity : 2 candela.
- Works with 4 alkaline batteries R20 (not included).
- Dimensions : 360 x 100 mm (H x Ø).

Operation principle of fixed light

- The spring is in permanent contact with the base of the bulb and the positive terminal of the batteries.
- The wire is in permanent contact with bulb socket.

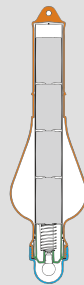

When not in use, the weight of the batteries compresses the spring and shuts off the contact between wire and batteries negative terminal.

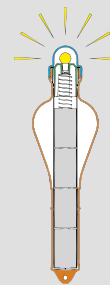

When the light is thrown into the water, it floats in vertical position immediately, thanks to its specific shape. The batteries slide down in the tube and, with their weight, create the contact with the wire connected to the bulb.

Accessory

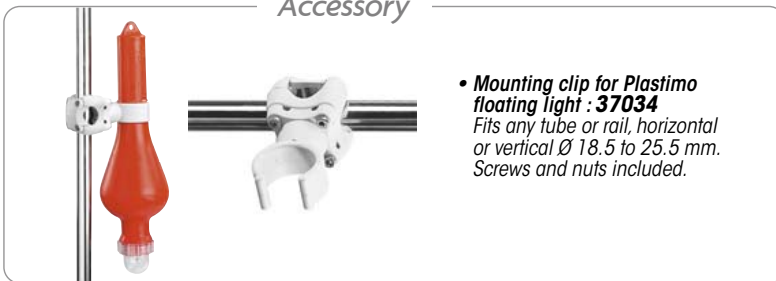

- **Mounting clip for Plastimo floating light : 37034**
Fits any tube or rail, horizontal or vertical Ø 18.5 to 25.5 mm. Screws and nuts included.

Spare part

- **Bulb : 54499**



SOLAS

Ultra compact LED flashlight 64047

Among the most compact and lightest on the market. Triggered automatically when the light is disengaged from its support. Can be used on platforms (drop test at 76 m validated).

- Visibility radius : 360.
- Duration : 2 hours minimum.
- Output : 2 candela minimum.
- Weight : 91 g (light only), 115 g (light and holder).
- Dimensions : light only 75 x 78 mm (Ø x H).
light with holder 86 x 97 mm.
- Supplied with polypropylene holder and 1 m lanyard to attach to lifebuoy.

SOLAS-MED &
US Coastguards compliant



196482

Stella LED flashlight 196482

Very compact lifebuoy light, low power consumption. LED-type flashlight, operates with one R20 alkaline battery. 360° arc of visibility.

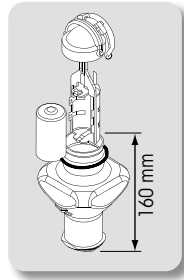

63655

Sirius LED flashlight 63655

Floating LED-type lifebuoy with **automatic seawater activation**. Can be stored in any position with no risk of inadvertent activation. Circuit and lithium battery are sheltered and locked in polyurethane foam to avoid oxydation.

Model	Stella : 196482	Sirius : 63655
Activation	By turning over	With seawater contact*
Arc of visibility	360°	360°
Duration	Approx. 8 hours	> 12 hours
Flash	60 flash/minute	ND (50-70 flash/minute)
Light intensity	2 candela	3 candela
Battery	R20 alkaline battery (x1) - not included	Integrated lithium battery (5-year run time)
Weight	90 g. (without battery)	310 g
Dimensions	160 x 80 x 80 mm	220 x 100 mm (H x Ø)
Supplied with	-	Holder and 2,65 m lanyard
Accessory	Mounting clip ref.	-

* Can be stored in any position without risk of accidental ignition.

Accessory



• **Mounting clip : 45184**
Fits any tube or rail, horizontal or vertical Ø 20 to 30 mm. Screws not included.

Life Flag

Photoluminescent and fluorescent : visible at any time night or day, the Life Flag enables a quick and effective location. Available in distress and diving flag.

Innovative process

Photoluminescence process combined with fluorescence optimizes the location by night or day, in all weather conditions. 5 minutes exposure to a bright light = 8 hours of photoluminescence.

Benefits

- **Safety** : excellent visibility by night or day, immediate spotting even from airplane.
- **Easy to use** : quick and easy fastening with shock cords, fully operational when flat or hoisted.
- **Economic and eco-friendly** : durable safety equipment, recyclable. No other energy source required other than light.
- **Quality** : made in France, non-polluting manufacturing process with solvent-free, water based printing paste. French patent. LNE certificate.

International maritime distress flag 61689	Diving flag with Saint-Andrew's cross 61690
Dimensions : 75 x 112 cm	Dimensions : 30 x 40 cm
Weight < 320 g	Weight < 50 g
Blocked mesh polyester fabric, 130 g/m ²	Blocked mesh polyester fabric, 130 g/m ²
Tunnel strap (Life Flag exclusivity)	Tunnel strap (Life Flag exclusivity)
Supplied with 4 shock cords	Supplied with 4 shock cords
Complies with OMI/RIPAM-IMO/COLREG distress signals (flag with black ball)	-



To be rescued,
we must be seen

For recreational boating,
sailing and windsurfing,
or all water activities.



61689 - Day



61689 - Night



61690 - Day



61690 - Night

Bailing out

(see also Pumps Chapter)



Hand pump



Pump alone	Pump + 1 m hose	Output per stroke	Min. dimensions	Stroke
14089	27074	0.50 L	480 mm	330 mm
14105	27075	0.75 L	630 mm	480 mm
14090	27076	1 L	790 mm	640 mm

25 m hose Ø 25 mm : **16209**

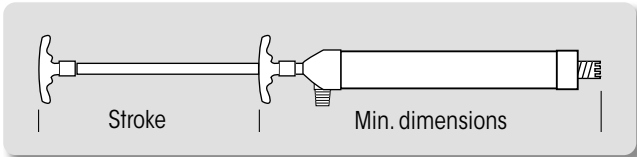

Plastic bucket

Handle with a loop for the rope.
Capacity : 10 L.

Model	Ref.	
Bucket without rope	14375	1
Bucket with rope	17576	5



Rubber bucket

14054
Aluminium handle.
Capacity : 7.5 L.
Height : 23 cm.
Ø : 26 cm.



Canvas collapsible bucket



182510
25 cm diameter canvas collapsible bucket with stainless steel handle. Zippered storage cover. Coated and sealed acrylic fabric.



Wooden plugs

16323 : Set of 9 conical wooden plugs :
2 x 40 mm high x Ø 10-4 mm*
2 x 50 mm high x Ø 16-8 mm*
2 x 60 mm high x Ø 22-14mm*
2 x 70 mm high x Ø 30-18 mm*
1 x 80 mm high x Ø 35-25 mm*

47428 : Set of 6 conical wooden plugs :
2 x high 60 mm x Ø 22-15 mm*
1 x high 115 mm x Ø 22-19 mm*
1 x high 110 mm x Ø 39-29 mm*
2 x high 110 mm x Ø 49-39 mm*
* Max.min diameter

10103 : Set of 9 conical wooden plugs :
3 x 110 mm high x Ø 29-19 mm*
3 x 110 mm high x Ø 39-29 mm*
3 x 110 mm high x Ø 50-40 mm*

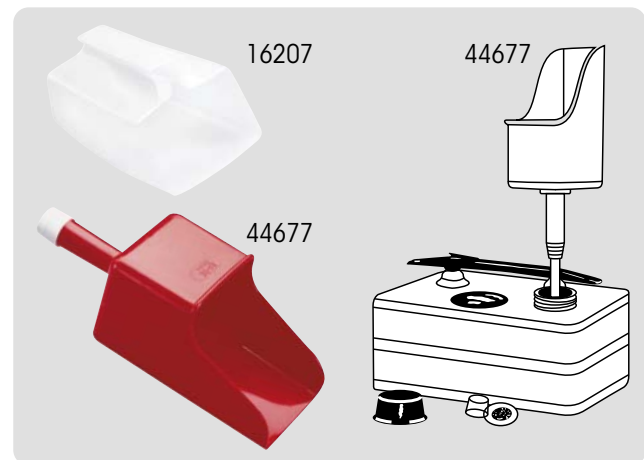

Bailers

	Dimensions	Reference
Floating, flexible bailer	180 x 125 mm (L x w)	16207
Bailer-funnel with filter	290 x 110 mm (L x w)	44677

Flushmount safety ladder

51558

Helps any crewmember get back on board easily without external help.

Suitable for current use (bathing) or in case of Man Over Board.

Consists of 3 polypropylene steps and 1 st. steel handle assembled by a highly resistant line, (bright yellow Ø 3 mm polyester).

Ladder is stored in a polyamide tube with a grey polypropylene cap, for optimum protection and waterproofness.

The Man Over Board removes the cap, pulls the ladder down, and climbs onboard.

- Light.
- Very easy flush mount (like a thru-hull fitting).
- Transom or skirt mount (sail and power boats), just above waterline.

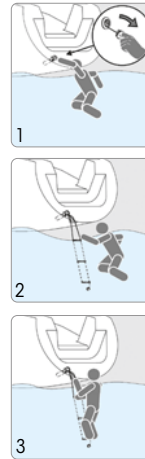
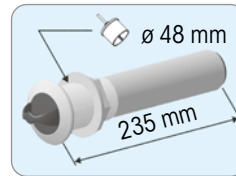
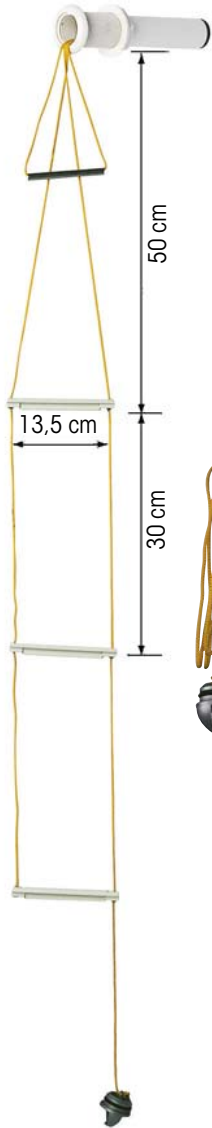

Safety ladder

• 4 steps : 29008

• 5 steps : 29009

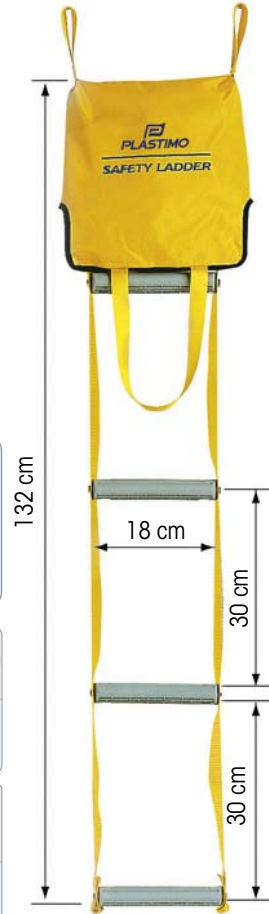

Designed to increase safety on board, this ladder comes in a canvas bag with 2 handles : one handle to attach the bag alongside the boat ; the other handle for the man fallen overboard to grab. The bag pulls open and the ladder unfolds instantly, helping the person to get back on board easily.

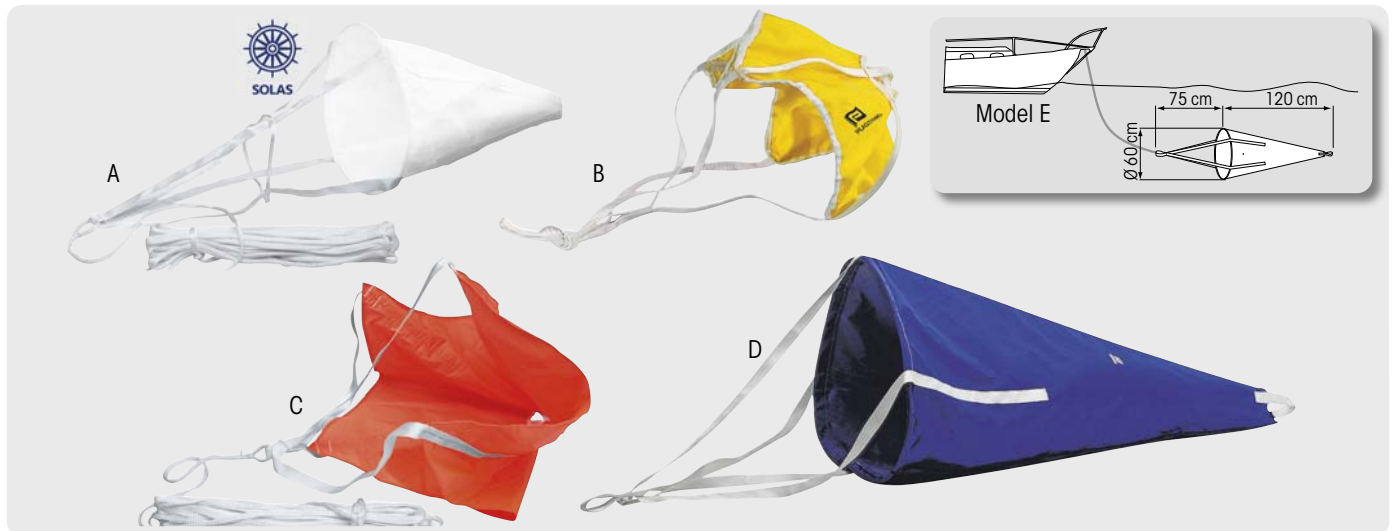

Sea anchor

Highly resistant models. Easily folded for storage.

Model	Ref.	Dimensions	Material	Line	Type of use
A - SOLAS	52957	Length 60 cm - Ø 40 cm	PVC coated mesh fabric	30 m line	SOLAS liferafts, up to 10-person
B	25354	Length 80 cm - Width 35 cm	Polyester fabric	-	Horseshoe buoy, Dan buoy, etc.
C	52559	Length 90 cm - Width 75 cm	PVC coated fabric	30 m line	ISO 9650 liferafts, from 4 to 10 persons
D	18668	Length 120 cm - Ø 60 cm	PVC coated fabric	-	Sailboats & Powerboats



BAINBRIDGE

INTERNATIONAL

NORTHEAST

255 Revere Street
Canton, MA. 02021

Tel: 781.821.2600
Fax: 781.821.2609
Toll-Free: 800.422.5684

SOUTHEAST

2580 North Powerline Road
Suite 603 & 604
Pompano Beach, FL. 33069

Tel: 954.532.7557
Fax: 954.366.3362
Toll-Free: 855.599.7741

WEST

15242 Transistor Lane
Huntington Beach, CA. 92649

Tel: 714.373.3322
Fax: 714.373.3326
Toll-Free: 800.433.0101

info@bainbridgeintusa.com

www.bainbridgeintusa.com